

# Managing Fall Protection Hazards Workbook

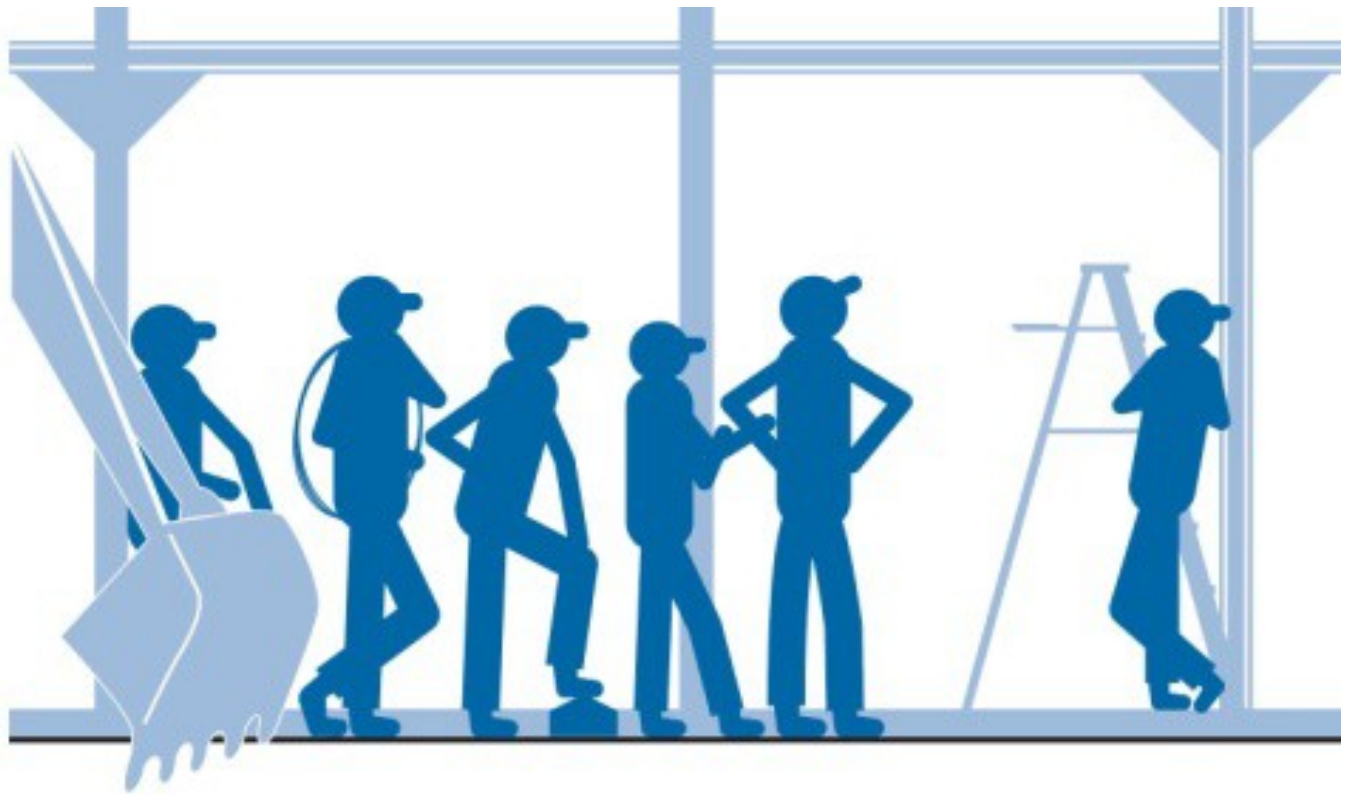

# Latino Worker Resource Center

## *WELCOME...*

*Falls are the leading cause of death in construction. When working from heights, such as ladders, scaffolds, and roofs, employers must plan projects to ensure that the job is done safely. This is not the place to cut corners or cheat on safety. It's your life hanging in the balance, so pay attention and know what it takes to keep you safe.*

This publication contains:

1. The purpose for the Occupational Safety and Health Administration (OSHA) and its enforcement duty under law.
2. Important terms and definitions within OSHA's fall protection standard, specifically *competent person*.
3. The nature of fall hazards in construction.
4. Procedures for erecting, maintaining, disassembling, and inspecting fall protection systems.
5. The use and operation of guardrail systems, personal fall arrest systems, safety net systems, warning line systems, safety monitoring systems, controlled access zones, and other protection to be used.
6. Emergency response procedures.
7. OSHA's standards and references.



**(888) 595-5972**

**[www.latinoworker.org](http://www.latinoworker.org)**

**Copyright ©2015**

---

The content of this *Managing Fall Protection Hazards Handbook* is mostly taken from OSHA's fall protection standards 29 CFR 1926 Subpart M and other standards. Other contributions come from OSHA Letters of Interpretation, OSHA Fact Sheets and posters. Additional information on scaffolds, steel erection, general industry and stairways & ladders is also provided. The Construction Safety Council will also like to acknowledge the following for their support as well...

- The Occupational Safety and Health Administration (OSHA)
- CPWR – The Center for Construction Research and Training (eLCOSH images)
- Oregon OSHA

---

### **GENERAL DISCLAIMER**

This material is not a substitute for any provision of the Occupational Safety and Health Administration (OSHA) or any standards issued by OSHA. If at any time it is discovered that the materials presented vary from Federal or State OSHA regulations, American National Standards Institute (ANSI), state laws or local ordinances, it is understood that those regulations, laws and ordinances will take precedence over the materials presented herein. In some cases, the information given may imply a higher level of protection than required in some Federal or State OSHA regulations. The mention of any products or materials by brand name in no way constitutes endorsement. Any products or materials not mentioned within this manual that may be considered acceptable as protective devices, equipment, or practices is not intentional and should not rule out their acceptability as employee or environmental protection.

### **OSHA DISCLAIMER**

This material was produced under grant number Susan Harwood Grant # SH26315-SH4 during Grant Year 2014 from the Occupational Safety and Health Administration, U.S. Department of Labor. It does not necessarily reflect the views or policies of the U.S. Department of Labor, nor does mention of trade names, commercial products, or organizations imply endorsement by the U.S. Government.

Finally, this *Managing Fall Protection Hazards Handbook* is intended to be used as a training aid and for general information only; the creator assumes no responsibility for any loss or damage resulting from its use.

---

## COURSE DESCRIPTION

### **Reasons for Development**

- Protect the safety and health of the worker.
- Train competent persons to perform frequent and regular inspections of the job-site, materials and equipment.
- Help employers understand and react to fall hazards in construction and comply with Federal rules and regulations.

#### **Employers have the responsibility to:**

- (1) Develop safety programs to comply with OSHA standards.
- (2) Provide for frequent and regular inspections of the job-sites, materials, and equipment to be made by competent persons designated by the employers.
- (3) Not allow the use of any machinery, tool, material, or equipment which is not in compliance with any applicable requirement of [OSHA]. Such machine, tool, material, or equipment shall either be identified as unsafe by tagging or locking the controls to render them inoperable or shall be physically removed from its place of operation.
- (4) The employer shall permit only those employees qualified by training or experience to operate equipment and machinery.

#### **Employer's responsibility to train workers:**

- (1) The employer should avail himself of the safety and health training programs the Secretary provides.
- (2) The employer shall instruct each employee in the recognition and avoidance of unsafe conditions and the regulations applicable to his work environment to control or eliminate any hazards or other exposure to illness or injury.

### **Course Goal**

The goal of this course is to enhance communication of fall hazards between employers & employees and to prevent accidents. At the conclusion, each course participant will possess the confidence to recognize and avoid unsafe conditions and behaviors as well as be able to identify regulations applicable to fall hazards in construction.

- Train competent persons.
- Become more aware of fall hazards in construction and function within a safety management system.

### **Course participants will learn**

- Occupational Safety & Health Administration (OSHA) fall protection standards.
- The correct procedures for erecting, maintaining, disassembling and inspecting fall protection systems.
- How and when to make managerial decisions, such as how to implement a job-site *Fall Management System*.

### **Intended Audience**

The target audience is the construction employer, manager, employee or employee representative who, as part of a safety and health program, would either be acting to fulfill the requirements of a competent person (to conduct frequent and regular inspections of a job-site) or performing safety and health evaluations for their member employees and performing training as described in OSHA's construction safety & health standard 29 CFR 1926.

- Job-site Competent Persons
- Qualified Persons
- Site Supervisors
- Owners

# TABLE OF CONTENTS

	<u>Page</u>
<b>Contents</b>	
<b><i>Important Terms &amp; Definitions</i></b> .....	1
<b><i>Contractor Fall Management System</i></b> .....	1
<b><i>Occupational Safety &amp; Health Administration (OSHA)</i></b> .....	2
<b>Fall Fatalities in Construction</b> .....	3
<b>Reporting of Fatalities and Catastrophes</b> .....	3
<b>Refusing to Work because Conditions are Dangerous</b> .....	6
<b>OSHA’s Multi-Employer Worksite Citation Policy</b> .....	7
<b>Your Rights as a Whistleblower</b> .....	8
<b>Whistleblower Laws Enforced by OSHA</b> .....	8
Under the following laws, complaints must be filed in writing: .....	8
<b>Unfavorable Personnel Actions</b> .....	8
<b>Filing a Complaint</b> .....	8
<b>Your Rights as a Whistleblower</b> .....	9
<b>How OSHA Determines Whether Retaliation Took Place</b> .....	9
<b><i>Employers must Provide and Pay for most Personal Protective Equipment (PPE)</i></b> .....	11
<b>Personal Protective Equipment (PPE)</b> .....	11
<b>Employers Must Pay for Personal Protective Equipment (PPE)</b> .....	11
<b><i>Federal Standards (Construction, Part 1926)</i></b> .....	12
<b>Subpart M</b> .....	12
<b>Subpart L</b> .....	12
<b>Subpart R</b> .....	12
<b><i>Federal Standards (Construction, Part 1926)</i></b> .....	13
<b>Subpart X</b> applies to all stairways and ladders used in construction, alteration, repair (including painting and decorating), and demolition workplaces covered under part 1926 (construction), and also sets forth, in specific circumstances, when ladders and stairways are required to be provided. ....	13
<b>Subpart D (29 CFR Part 1910)</b> applies to all permanent places of employment. ....	13
<b><i>American Society of Safety Engineers (ANSI A10.32)</i></b> .....	14
<b><i>American Society of Safety Engineers (ANSI Z359)</i></b> .....	14
<b><i>Qualified Person</i></b> .....	15
<b><i>Competent Person</i></b> .....	17

## TABLE OF CONTENTS

<i>“Safety Pays – Falls Cost”</i> .....	19
<i>Discussion Points Fall Protection Systems</i> .....	21
<i>Conventional and Alternative Fall Protection Systems</i> .....	22
Guardrail Systems .....	23
<i>General Guidelines</i> .....	24
Safety Net Systems .....	25
Personal Fall Arrest Systems .....	27
Full Body Harness .....	28
Lanyards .....	28
Rope Grabs .....	29
Shock Absorbers .....	30
Lifelines .....	31
<i>Horizontal Lifeline:</i> .....	32
<i>Lifeline Anchors</i> .....	33
<i>Attaching Anchors</i> .....	34
<i>Using Fall Arrest Systems Safely</i> .....	34
<i>Distance of Fall</i> .....	35
Height of .....	<b>Error! Bookmark not defined.</b>
Inspection and Maintenance of Personal Fall Arrest Systems .....	37
<i>Harness Inspection</i> .....	37
<i>Lanyard Inspection</i> .....	38
<i>Shock-Absorbing Packs Inspection</i> .....	39
<i>Visual Indication of Damage to Webbing and Rope Lanyards</i> .....	39
<i>Cleaning of Equipment</i> .....	39
Positioning Device Systems .....	40
Restraint Systems .....	41
Hole Covers .....	42
Holes .....	42
<i>Walking / Working Surfaces</i> .....	44
<i>Protection from Falling Objects</i> .....	45
<i>Custody of Fall Protection</i> .....	46
<i>Warning Line Systems</i> .....	47
<i>Controlled Access Zone</i> .....	48

## TABLE OF CONTENTS

<b><i>Controlled Decking Zone (CDZ)</i></b> .....	49
<b><i>Safety Monitoring Systems</i></b> .....	50
<b><i>Fall Protection Plans</i></b> .....	51
<b><i>Discussion Points</i></b> .....	52
<b>Walking/Working Surfaces Strength and Integrity</b> .....	52
<b>Housekeeping</b> .....	52
<b>Unprotected Sides &amp; Edges</b> .....	53
<b>Leading Edges</b> .....	53
<b>Hoist Areas</b> .....	53
<b>Holes</b> .....	54
<b>Formwork &amp; Reinforcing Steel</b> .....	54
<b>Ramps, Runways/Walkways</b> .....	54
<b>Excavations</b> .....	55
<b>Dangerous Equipment</b> .....	55
<b>Overhand Bricklaying</b> .....	56
<b>Roofing Work on Low-sloped Roofs</b> .....	56
<b>Steep Roofs</b> .....	56
<b>Precast Concrete Erection</b> .....	57
<b>Residential Construction</b> .....	58
<b>Wall Openings</b> .....	59
<b>Walking/Working Surfaces not otherwise Addressed</b> .....	59
<b><i>Introduction Stairs and Ladders</i></b> .....	60
<b>General Requirements</b> .....	60
<b>Rules for Ladders</b> .....	61
<b>Specific Types of Ladders</b> .....	62
<b><i>Stepladders</i></b> .....	62
<b><i>Portable Ladders</i></b> .....	62
<b><i>Fixed Ladders</i></b> .....	64
<b><i>Cages for Fixed Ladders</i></b> .....	65
<b><i>Wells for Fixed Ladders</i></b> .....	65
<b>Ladder Safety Devices and Related Support Systems for Fixed Ladders</b> .....	65
<b><i>Requirements for Mounting Ladder Safety Devices for Fixed Ladders</i></b> .....	66
<b><i>Defective Ladders</i></b> .....	66

## TABLE OF CONTENTS

Wooden Ladders .....	67
Aluminum Ladders .....	67
Job-Built Ladders .....	67
Ladder Use.....	68
Inspection and Maintenance .....	69
Ladder Safety Checklist .....	70
<hr/>	
.....	70
Criteria for Ladder Purchase and Care.....	70
<i>Temporary Stairs</i> .....	71
Stair Rails .....	71
Handrails .....	72
Midrails.....	72
<i>Aerial Lifts – OSHA Fact Sheet</i> .....	73
Training .....	73
Retraining.....	73
What to Do Before Operating an Aerial Lift .....	74
Lift components .....	74
Work Zone Inspections .....	74
What to Do While Operating an Aerial Lift.....	75
Fall Protection:.....	75
Operation/Traveling/Loading: .....	75
Overhead Protection:.....	75
Stability in the Work Zone: .....	75
Standards that Apply .....	75
<i>Scaffolding</i> .....	76
Crossbracing .....	78
*Crossbracing can be used as a top-rail, mid-rail, or neither, but never both* .....	79
29CFR1926 Subpart M.....	80



## **Discussion Points**

- Important Terms & Definitions within OSHA's Federal fall protection standards.
- OSHA's purpose/*General Duty Clause*.
- Employer/employee rights & responsibilities under the OSH Act.
- OSHA's Multi-Employer Worksite Citation Policy.
- OSHA's Federal standards addressing falls.
- Industry Consensus Standards for fall protection equipment and programs.
- *Fall Prevention in Construction Campaign – Plan, Provide, Train.*

## **Important Terms & Definitions**

- Fall Management System
- General Duty Clause
- OSHA Act
- Multi-Employer Worksite Citation Policy
- Creating Employer
- Exposing Employer
- Correcting Employer
- Controlling Employer
- Federal Standards
- Industry Consensus Standards
- Qualified Person
- Competent Person

---

## **Contractor Fall Management System**

A *Site-specific Fall Protection Plan* may include the following elements:

- **Management Commitment & Employee Involvement**
  - ✓ Knowledge of OSHA Standards
  - ✓ Knowledge of Industry Consensus Standards
  - ✓ Fall Management Policy & Accountability Plan
- **Work-site Analysis**
  - ✓ Pre-job Planning
  - ✓ Job-site Inspection Check-lists
- **Hazard Prevention & Controls**
  - ✓ Fall Protection Systems & Criteria
  - ✓ Rescue Plan
- **Safety & Health Training**
  - ✓ Certification of Training
  - ✓ Employees (Workers)
  - ✓ Competent Persons
  - ✓ Retraining

## **Occupational Safety & Health Administration (OSHA)**

### ***OSHA's Purpose...***

To assure safe and healthful working conditions for working men and women; by authorizing enforcement of the standards developed under the Act; by assisting and encouraging the States in their efforts to assure safe and healthful working conditions; by providing for research, information, education, and training in the field of occupational safety and health; and for other purposes.

Be it enacted by the Senate and House of Representatives of the United States of America in Congress assembled, that this Act may be cited as the "Occupational Safety and Health Act of 1970" (OSH Act).



---

### ***General Duty Clause...***

#### ***(a) Each employer***

***(1) Shall furnish to each of his employees employment and a place of employment which are free from recognized hazards that are causing or are likely to cause death or serious physical harm to his employees.***

***(2) Shall comply with occupational safety and health standards promulgated under this Act.***

***(b) Each employee shall comply with occupational safety and health standards and all rules, regulations, and orders issued pursuant to this Act which are applicable to his own actions and conduct.***

---

### ***What is OSHA's General Duty Clause?***

Section 5(a)(1) of the OSH Act has become known as "The General Duty Clause". It is a catch all for citations if OSHA identifies unsafe conditions to which a regulation does not exist.

In practice, OSHA, court precedent, and the review commission have established that if the following elements are present, a "general duty clause" citation may be issued.

1. An employer failed to keep the workplace free of a hazard to which employees of that employer were exposed.
2. The hazard was recognized. (Examples: Equipment Manufacturer Manuals, other Industry and Council associated manuals, through job-site safety personnel, employees, trade unions and other associations/organizations like ANSI.)
3. The hazard was causing or was likely to cause death or serious physical harm.
4. There was a feasible and useful method to correct the hazard.

**Fall Fatalities in Construction**

Falls are the leading cause of death in construction. One of every three construction fatalities are as a result of falls. The U.S. Department of Labor (DOL) investigates these fatalities and reports them to the Bureau of Labor Statistics (BLS). Visit [www.osha.gov](http://www.osha.gov) for a recent listing of current fatalities and catastrophes.

**Reporting of Fatalities and Catastrophes**

OSHA Standard, 29 CFR Subpart 1904.39, *Reporting Fatality, Injury and Illness Information to the Government* requires that employers report all work related fatalities within eight (8) hours and all work-related inpatient hospitalizations, all amputations and all losses of an eye within 24 hours. Employers must orally report the fatality/hospitalization by telephone or in person to the OSHA Area Office or to the State Plan Office that is nearest to the site of the incident. Employers may also use the OSHA toll-free central telephone number, 1-800-321-OSHA (1-800-321-6742). These reports must also be reflected on the 300 log and other data keeping requirements per 1904.42, and per 1910.217(g) for Mechanical Power Press amputations.

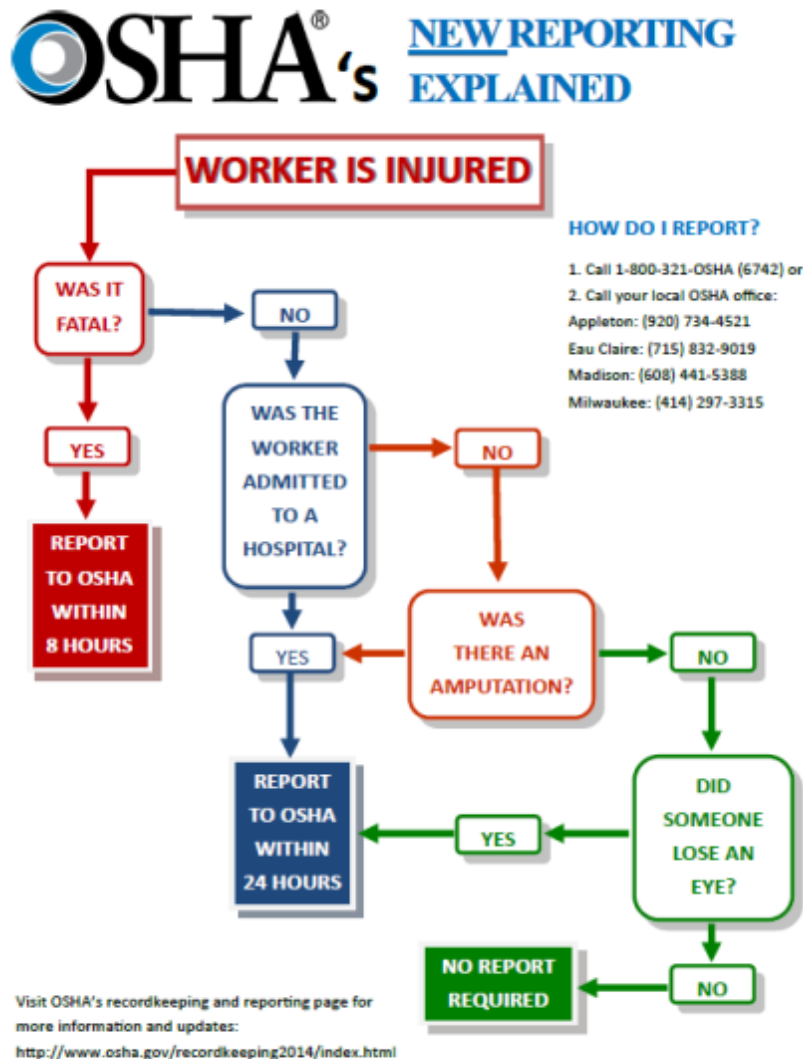

## **Fatal Fact #1**

A full time carpenter was working on the second floor of a wood framed (new construction) residential house, when he fell more than 20 feet through an unguarded stairway opening to the concrete basement floor. He was killed in the fall from fatal head and internal injuries.



## **Fatal Fact #2**

A worker was installing vinyl siding on a two story town home. He was using a ladder that was placed on top of a scaffold. While standing on the top step of the ladder, the worker overreached to one side and the ladder overturned. He fell nearly 20 feet to the driveway below. He died later that day from injuries caused by the fall.



## **Fatal Fact #3**

Four workers were installing sheet metal steel decking on a pre-engineering building. As one of the workers walked down the roof, he lost his footing and fell through an opening. He died the next day from injuries caused by the fall.



## **Fatal Fact #4**

Two workers were re-roofing a two story home with a pitched roof. One of the workers was close to the edge of the roof. As she reached to pick up another shingle, she lost her balance and fell more than 20 feet to the driveway below. She died instantly from her injuries.



## INTRODUCTION TO OSHA

**Job Safety and Health**  
**IT'S THE LAW!**

**OSHA**  
**Occupational Safety & Health Administration**  
**U.S. Department of Labor**

### EMPLOYEES:

- You have the right to notify your employer or OSHA about workplace hazards. You may ask OSHA to keep your name confidential.
- You have the right to request an OSHA inspection if you believe that there are unsafe and unhealthful conditions in your workplace. You or your representative may participate in that inspection.
- You can file a complaint with OSHA within 30 days of retaliation or discrimination by your employer for making safety and health complaints or for exercising your rights under the OSH Act.
- You have a right to see OSHA citations issued to your employer. Your employer must post the citations at or near the place of the alleged violation.
- Your employer must correct workplace hazards by the date indicated on the citation and must certify that these hazards have been reduced or eliminated.
- You have the right to copies of your medical records or records of your exposure to toxic and harmful substances or conditions.
- Your employer must post this notice (OSHA 3165-12-06R) in your workplace.
- You must comply with all occupational safety and health standards issued under the *OSH Act* that apply to your own actions and conduct on the job.

### EMPLOYERS:

- You must furnish your employees a place of employment free from recognized hazards.
- You must comply with the occupational safety and health standards issued under the *OSH Act*.

**This free poster available from OSHA - *the Best Resource for Safety and Health***

Free assistance in identifying and correcting hazards or complying with standards is available to employers, without citation or penalty, through OSHA-supported consultation programs in each state.

1-800-321-OSHA  
[www.osha.gov](http://www.osha.gov)

OSHA 3165-12-06R

**Refusing to Work because Conditions are Dangerous**

Workers have the right to refuse to do a job if they believe in good faith that they are exposed to an *imminent danger*. “Good faith” means that even if an imminent danger is not found to exist, the worker had reasonable grounds to believe that it did exist.

***Refusing work is protected if...***

***Your right to refuse to do a task is protected if all of the following conditions are met:***

- Where possible, you have asked the employer to eliminate the danger, and the employer failed to do so; and
- You refused to work in “good faith.” This means that you must genuinely believe that an imminent danger exists. Your refusal cannot be a disguised attempt to harass your employer or disrupt business; and
- A reasonable person would agree that there is a real danger of death or serious injury (illness); and
- There isn’t enough time, due to the urgency of the hazard, to get it corrected through regular enforcement channels, such as requesting an OSHA inspection.

***When all of these conditions are met, you take the following steps:***

- Ask your employer to correct the hazard;
- Ask your employer for other work;
- Tell your employer that you won’t perform the work unless and until the hazard is corrected; and
- Remain at the worksite until ordered to leave by your employer.

IF	THEN
You believe working conditions are unsafe or unhealthful.	Call your employer’s attention to the problem.
Your employer does not correct the hazard or disagrees with you about the extent of the hazard.	You may file a complaint with OSHA.
Your employer discriminates against you for refusing to perform the dangerous work	Contact OSHA immediately. (800) 321-OSHA

## OSHA's Multi-Employer Worksite Citation Policy

When on a construction job-site, multiple employers and employees are exposed to a variety of hazards that may or may not have been created or under the control of any one employer. Because of this “*multi-employer*” relationship, more than one employer may be citable for a hazardous condition that violates an OSHA standard. (**Note:** this also applies where construction / maintenance activities by contractors occur in general industry worksite projects)

OSHA classifies employers into one or more of four categories – the ***creating, exposing, correcting, and controlling employers*** – to determine if a citation will be issued.

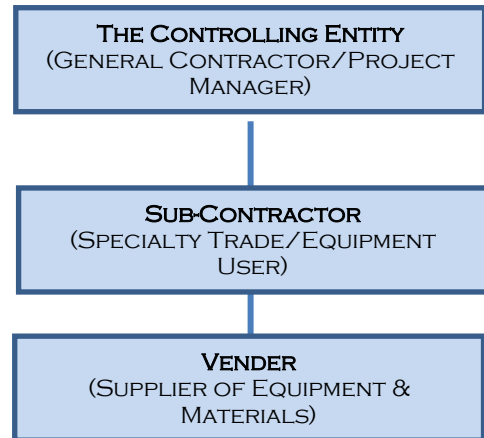

**The Creating Employer:** an employer who causes a hazardous condition that violates an OSHA standard. An employer who creates the hazard is citable even if the only employees exposed in the workplace are those who work for other employers

**The Exposing Employer:** an employer whose own employees are exposed to the hazard.

If the exposing employer created the violation, he/she is citable for the violation as a creating employer.

If the violation was created by another employer, the exposing employer is citable if he/she:

- 1) Knew of the hazardous condition or failed to exercise reasonable diligence to discover the condition, and
- 2) Failed to take steps to protect his/her employees.

If the exposing employer has the authority to correct the hazard, he/she must do so.

If he/she lacks the authority to correct the hazard, he/she is citable if he/she fails to do each of the following:

- 1) Ask the creating and/or controlling employer to correct the hazard
- 2) Inform his/her employees of the hazard, and
- 3) Take reasonable alternative protective measures.

**NOTE:** In some circumstances, the employer is citable for failing to remove his/her employees from the job to avoid the hazard

**The Correcting Employer:** an employer who is responsible for correcting a hazard on the exposing employer’s worksite, usually occurring while the correcting employer is installing and/or maintaining safety/health equipment. The correcting employer must exercise reasonable care in preventing and discovering violations and meet his/her obligation of correcting the hazard.

**The Controlling Employer:** an employer who has general supervisory authority over the worksite, including the power to correct safety and health violations or requiring others to correct them. A controlling employer must exercise reasonable care to prevent and detect violations on the site.

## Your Rights as a Whistleblower

You may file a complaint with OSHA if your employer retaliates against you by taking unfavorable personnel action because you engaged in protected activity relating to workplace safety and health, commercial motor carrier safety, pipeline safety, air carrier safety, nuclear safety, the environment, asbestos in schools, corporate fraud, SEC rules or regulations, railroad carrier safety or security, or public transportation agency safety or security.

### **Whistleblower Laws Enforced by OSHA**

Each law requires that complaints be filed within a certain number of days after the alleged retaliation.

You may file complaints by telephone or in writing under the:

- Occupational Safety and Health Act (30 days)
- Surface Transportation Assistance Act (180 days)
- Asbestos Hazard Emergency Response Act (90 days)
- International Safe Container Act (60 days)
- Federal Rail Safety Act (180 days)
- National Transit Systems Security Act (180 days)

Under the following laws, complaints must be filed in writing:

- Clean Air Act (30 days)
- Comprehensive Environmental Response, Compensation and Liability Act (30 days)
- Energy Reorganization Act (180 days)
- Federal Water Pollution Control Act (30 days)
- Pipeline Safety Improvement Act (180 days)
- Safe Drinking Water Act (30 days)
- Sarbanes-Oxley Act (90 days)
- Solid Waste Disposal Act (30 days)
- Toxic Substances Control Act (30 days)
- Wendell H. Ford Aviation Investment and Reform Act for the 21st Century (90 days)

### **Unfavorable Personnel Actions**

Your employer may be found to have retaliated against you if your protected activity was a contributing or motivating factor in its decision to take unfavorable personnel action against you. Such actions may include:

- Firing or laying off

- Blacklisting
- Demoting
- Denying overtime or promotion
- Disciplining
- Denying benefits
- Failing to hire or rehire
- Intimidation
- Reassignment affecting promotion prospects
- Reducing pay or hours

### **Filing a Complaint**

If you believe that your employer retaliated against you because you exercised your legal rights as an employee, contact your local OSHA office as soon as possible, because you must file your complaint within the legal time limits. OSHA conducts an in-depth interview with each complainant to determine whether to conduct an investigation.

For more information, call your closest OSHA Regional Office. Addresses, fax numbers and other contact information for these offices can be found on OSHA's website, [www.osha.gov](http://www.osha.gov), and in local directories. Some complaints must be filed in writing and some may be filed verbally (call your local OSHA office for assistance).

Written complaints may be filed by mail (recommend certified mail), fax, or hand-delivered during business hours. The date postmarked, faxed or hand delivered is considered the date filed.

If retaliation for protected activity relating to occupational safety and health issues takes place in a state that operates an OSHA-approved state plan, the complaint should be filed with the state agency, although persons in those states may file with Federal OSHA at the same time. Although the Occupational Safety and Health Act covers only private sector employees, state plans also cover state and local government employees.



## Your Rights as a Whistleblower

### How OSHA Determines Whether Retaliation Took Place

- The investigation must reveal that:
- The employee engaged in protected activity;
- The employer knew about the protected activity;
- The employer took an adverse action; and
- The protected activity was the motivating factor (or under some laws, a contributing factor) in the decision to take the adverse action against the employee.

If the evidence supports the employee's allegation and a settlement cannot be reached, OSHA will issue an order requiring the employer to reinstate the employee, pay back wages, restore benefits, and other possible remedies to make the employee whole.

### Limited Protections for Employees Who Refuse to Work:

You have a limited right under the OSH Act to refuse to do a job because conditions are hazardous. You may do so under the OSH Act only when (1) you believe that you face death or serious injury (and the situation is so clearly hazardous that any reasonable person would believe the same thing); (2) you have tried to get your employer to correct the condition, and there is no other way to do the job safely; and (3) the situation is so urgent that you do not have time to eliminate the hazard through regulatory channels such as calling OSHA.

Regardless of the unsafe condition, you are not protected if you simply walk off the job. For details, see

<http://www.osha.gov/as/opa/worker/refuse.html>.

OSHA cannot enforce union contracts or state laws that give employees the right to refuse to work.

### Whistleblower Protections in the Transportation Industry:

Employees whose jobs directly affect commercial motor vehicle safety are protected from retaliation by their employers for refusing to violate or for reporting violations of Department of Transportation (DOT) motor carrier safety standards or regulations, or refusing to operate a vehicle because of such violations or because they have a reasonable apprehension of death or serious injury. Similarly, employees of air carriers, their contractors or subcontractors who raise safety concerns or report violations of FAA rules and regulations are protected from retaliation, as are employees of owners and operators of pipelines, their contractors and subcontractors who report violations of pipeline

safety rules and regulations. Employees involved in international shipping who report unsafe shipping containers are also protected. In addition, employees of railroad carriers or public transportation agencies, their contractors or subcontractors who report safety or security conditions or violations of federal rules and regulations relating to railroad or public transportation safety or security are protected from retaliation.

### Whistleblower Protections for Voicing

**Environmental Concerns:** A number of laws protect employees who report violations of environmental laws related to drinking water and water pollution, toxic substances, solid waste disposal, air quality and air pollution, asbestos in schools, and hazardous waste disposal sites. The Energy Reorganization Act protects employees who raise safety concerns in the nuclear power industry and in nuclear medicine.

### Whistleblower Protections When Reporting

**Corporate Fraud:** Employees who work for publicly traded companies or companies required to file certain reports with the Securities and Exchange Commission are protected from retaliation for reporting alleged mail, wire, or bank fraud; violations of rules or regulations of the SEC, or federal laws relating to fraud against shareholders.

**More Information:** To obtain more information on whistleblower laws, go to [www.osha.gov](http://www.osha.gov), and click on the link for "Whistleblower Protection."

NOTE: Other laws covered under OSHA's Whistleblower Law enforcement: -12 U.S.C.A. 5567 Consumer Financial Protection Act of 2010 (CFPA), Section 1057 of the Dodd-Frank wall Street Reform and Consumer Protection Act of 2010. -15 U.S.C 2087 Consumer Product Improvement Act (CPSIA) -49 U.S.C. 30171 Moving Ahead for Progress in the 21st Century Act (MAP-21) -46 U.S.C. 2114 Seaman's Protection Act, 46 U.S.C. 2114 (SPA), as amended by Section 611 of the Coast Guard Authorization Act of 2010,

## INTRODUCTION TO OSHA

P.L. 111-281 -21 U.S.C. 399d Section 402 of the FDA Food Safety Modernization Act (FSMA) New Whistleblower Regulations Interim Final Rule; Procedures for the Handling of retaliation Complaints: -29 CFR Part 1984, Section 1558 Affordable Care Act. -29 CFR Part 1985 Employee Protection Provision of the Consumer Financial Protection Act of 2010 -29 CFR Part 1987 Section 402 of the FDA Food Safety Modernization Act

**Employers must Provide and Pay for most Personal Protective Equipment (PPE)**

***Personal Protective Equipment (PPE)***

PPE is equipment worn to minimize exposure to a variety of hazards. Examples include items such as personal fall arrest systems, gloves, foot and eye protection, hearing protection, hard hats and respirators.

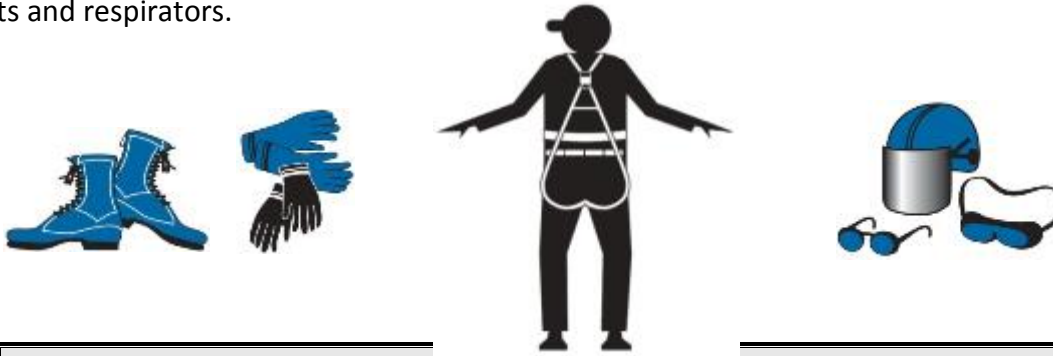

Employer Obligations	Worker Responsibility:
Perform a “hazard assessment” of the workplace to identify and control physical and health hazards. Identify and provide appropriate PPE for employees. Train employees in the use and care of the PPE. Maintain PPE, including replacing worn or damaged PPE. Periodically review, update and evaluate the effectiveness of the PPE program.	Properly wear PPE. Attend training sessions on PPE. Care for, clean and maintain PPE. Inform a supervisor of the need to repair or replace PPE.  <i>NOTE: The employer must pay for replacement PPE, except when the employee has lost or intentionally damaged the PPE.</i>

**Employers Must Pay for Personal Protective Equipment (PPE)**

With few exceptions, OSHA requires employers to pay for personal protective equipment used to comply with OSHA standards; employers cannot require workers to provide their own PPE. Even when a worker provides his or her own PPE, the employer must ensure that the equipment is adequate to protect the worker from hazards at the workplace.

***Employers are not required to pay for:***

***Everyday clothing;*** such as long-sleeve shirts, long pants and normal work boots (including protective toe).

***Ordinary clothing;*** such as winter coats, jackets and gloves.

# FEDERAL FALL PROTECTION STANDARDS

## **Federal Standards (Construction, Part 1926)**

Within the U.S. federal government (Federal OSHA), the most common referenced fall protection standard is 29 CFR 1926 Subpart M – *Fall Protection*. However, based on Subpart M exemptions, the specific fall protection requirements for Scaffolds are contained in Subpart L, for Steel Erection in Subpart R, and for Stairways & Ladders in Subpart X. In general industry (29 CFR Part 1910) requirements for *Walking-Working Surfaces* may also apply.

*NOTE: See complete OSHA rules (Parts 1910 & 1926) for all fall protection requirements.*

## 29 CFR 1926 Subpart M

(Department of Labor) (Code of Federal Regulations) (Construction Industry) (Fall Protection)

### ***Subpart M***

sets forth requirements and criteria for fall protection in construction workplaces covered under part 1926 (construction).

## 29 CFR 1926 Subpart L

(Department of Labor) (Code of Federal Regulations) (Construction Industry) (Scaffolds)

### ***Subpart L***

applies to all scaffolds used in workplaces covered by part 1926 (construction).

## 29 CFR 1926 Subpart R

(Department of Labor) (Code of Federal Regulations) (Construction Industry) (Steel Erection)

### ***Subpart R***

sets forth requirements to protect employees from the hazards associated with steel erection activities involved in the construction, alternation, and/or repair of single and multi-story buildings, bridges, and other structures where steel erection occurs.

**Federal Standards (Construction, Part 1926)**

**29 CFR 1926 Subpart X**

(Department of Labor) (Code of Federal Regulations) (Construction Industry) (Stairways & Ladders)

*Subpart X applies to all stairways and ladders used in construction, alteration, repair (including painting and decorating), and demolition workplaces covered under part 1926 (construction), and also sets forth, in specific circumstances, when ladders and stairways are required to be provided.*

**Federal Standards (General Industry, Part 1910)**

**29 CFR 1910 Subpart D**

(Department of Labor) (Code of Federal Regulations) (General Industry) (Walking-Working Surfaces)

**Subpart D (29 CFR Part 1910) applies to all permanent places of employment.** OSHA's directive on Fall Protection in General Industry (STD 01-01-013) defines a platform (walking-working surface) as any elevated surface designed or used primarily as a walking or working surface upon which employees are required or allowed to walk or work while performing assigned tasks on a *predictable and regular basis* (work performed once every two weeks or for a minimum of 4 man-hours during and 4 week period). For employee fall exposures from elevated surfaces on a predictable and regular basis the STD directs OSHA to regulate protection from falls by the standard railings (guardrails) regulations for uniform enforcement.

In situations where workers are exposed to falls from an elevated surface other than on a predictable and regular basis, the STD directs OSHA to regulate workers fall exposures by employee personal protective equipment (personal fall arrest systems/personal fall restraint systems) or other effective fall protection for uniform enforcement.

## ***American Society of Safety Engineers (ANSI A10.32)***

### **ANSI A10.32 – PERSONAL FALL PROTECTION USED IN CONSTRUCTION AND DEMOLITION OPERATIONS**

The A10.32 standard establishes performance criteria for personal fall protection equipment and systems in construction and demolition and provides guidelines, recommendations for their use and inspection.

The following is addressed in the Table of Contents (ANSI A10.32):

1. General	5.1 General Marking Requirements
1.1 Scope	5.2 Special Marking Requirements for Individual Components
1.2 Purpose	6. Employer Requirements
1.3 Application	6.1 Training
1.4 Resolutions	6.2 Rescue
2. Definitions	6.3 Inspection
3. General Requirements	6.8 Fall Restraint Systems
4. Performance Requirements	7. Test Requirements
4.1 Anchorage	7.1 Harness, Belt and Lanyard Performance Test Procedures
4.2 Fall Arrest	7.2 Lifeline Performance Test Procedures
4.3 Self-Retracting Lanyards (SRL)	7.3 Rope Grab Performance Test Procedures
4.4 Rope Grab	7.4 Hardware Test Procedures
4.5 Snaphooks and Carabiners	
4.6 Lanyards	
5. Marking Requirements	

---

## ***American Society of Safety Engineers (ANSI Z359)***

- ANSI Z359 was developed to provide standard safety requirements for personal fall arrest systems, subsystems, and components. Its primary purpose was to provide guidance in regards to the design of fall protection systems and the variety of equipment used in the industry.
- ANSI Z359.0 – DEFINITIONS AND NOMENCLATURE USED FOR FALL PROTECTION AND FALL ARREST
- ANSI Z359.1 – SAFETY REQUIREMENTS FOR PERSONAL FALL ARREST SYSTEMS, SUBSYSTEMS AND COMPONENTS
- ANSI Z359.2 – MINIMUM REQUIREMENTS FOR A COMPREHENSIVE MANAGED FALL PROTECTION PROGRAM
- ANSI Z359.3 – SAFETY REQUIREMENTS FOR POSITIONING AND TRAVEL RESTRAINT SYSTEMS
- ANSI Z359.4 – SAFETY REQUIREMENTS FOR ASSISTED-RESCUE AND SELF-RESCUE SYSTEMS, SUBSYSTEMS AND COMPONENTS
- ANSI Z359.6 – SPECIFICATIONS AND DESIGN REQUIREMENTS FOR ACTIVE FALL PROTECTION SYSTEMS
- ANSI Z359.7 – QUALIFICATION AND VERIFICATION TESTING OF FALL PROTECTION PRODUCTS
- ANSI Z359.12 – CONNECTING COMPONENTS FOR PERSONAL FALL ARREST SYSTEMS
- ANSI Z359.13 – PERSONAL ENERGY ABSORBERS AND ENERGY ABSORBING LANYARDS
- ANSI Z359.14 – SAFETY REQUIREMENTS FOR SELF-RETRACTING DEVICES FOR PERSONAL FALL ARREST AND RESCUE SYSTEMS

## QUALIFIED PERSON

### **Qualified Person**

**Qualified person** means a person who, by possession of a recognized degree, certificate, or professional standing, or who by extensive knowledge, training and experience, can successfully demonstrate the ability to solve/resolve problems relating to the subject matter, the work, or the project.

Per ANSI/ASSE Z359.0 definition of a Qualified Person is as follows: Qualified Person. A person with recognized degree or professional certificate and with extensive knowledge, training, and experience in the fall protection and rescue field who is capable of designing, analyzing, evaluating and specifying fall protection and rescue systems to the extent required by this standard.

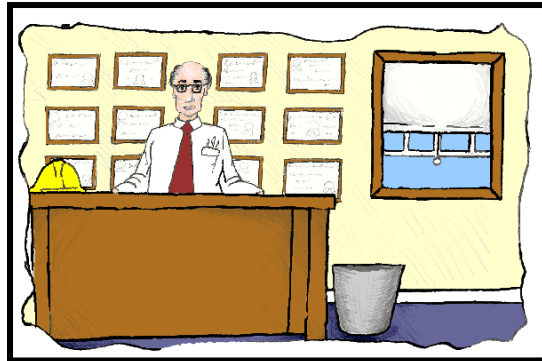

---

Within OSHA's fall protection standards, a "Qualified Person" may be required to ensure the proper design, installation and use of fall protection systems and plans. One of the more important aspects of a fall protection system is the *anchorage* point for personal fall arrest systems (PFAS's).

**Anchorage** means a secure point of attachment for lifelines, lanyards or deceleration devices.

Properly planned anchorages should be used if they are available. In some cases, anchorages must be installed immediately prior to use. In such cases, a registered professional engineer with experience in designing fall protection systems, or another **qualified person** with appropriate education and experience should design an anchor point to be installed.

In other cases, there will be a need to devise an anchor point from existing structures. Examples of what might be appropriate anchor points are steel members or I-beams if an acceptable strap is available for the connection; large eye-bolts made of an appropriate grade steel; guardrails or railings if they have been designed for use as an anchor point; or masonry or wood members only if the attachment point is substantial and precautions have been taken to assure that bolts or other connectors will not pull through. A **qualified person** should be used to evaluate the suitability of these "make shift" anchorages with a focus on proper strength.

---

### **§1926.502(d)(15) – Personal Fall Arrest Systems**

Anchorage used for attachment of personal fall arrest equipment shall be independent of any anchorage being used to support or suspend platforms and capable of supporting at least 5,000 pounds (22.2 kN) per employee attached, or shall be designed, installed, and used as follows:

As part of a complete personal fall arrest system which maintains a safety factor of at least two; and Under the supervision of a **qualified person**.

---

### **§1926.502(k)(1) – Fall Protection Plans**

## QUALIFIED PERSON

The fall protection plan shall be prepared by a **qualified person** and developed specifically for the site where the leading edge work, precast concrete work, or residential construction work is being performed and the plan must be maintained up to date.



## COMPETENT PERSON

### Competent Person

**Competent person** means one who is capable of identifying existing and predictable hazards in the surroundings or working conditions which are unsanitary, hazardous, or dangerous to employees, and who has authorization to take prompt corrective measures to eliminate them.



Per ANSI/ASSE Z359.0 definition of a Competent Person is as follows: Competent Person. An individual designated by the employer to be responsible for the immediate supervision, implementation, and monitoring of the employer's managed fall protection program who through training and knowledge, is capable of identifying, evaluating and addressing existing and potential fall hazards, and who has the employer's authority to take prompt corrective action with regard to such hazards.

- 
- Within OSHA's fall protection standards, a "*Competent Person*" is required to perform frequent and regular inspections of the job-site materials and equipment.
  - This person is designated by the employer and must have the authorization to take prompt corrective measures to eliminate hazards and enforce safety rules.
  - A competent person must also train each employee on how to recognize fall hazards and the procedures to be followed in order to minimize these hazards.
  - Personal fall arrest systems and components subjected to impact loading shall be immediately removed from service and shall not be used again for employee protection until inspected and determined by a **competent person** to be undamaged and suitable for reuse.
  - A personal fall arrest system is designed, tested, and supplied as a complete system. However, it is common practice for lanyards, connectors, lifelines, deceleration devices, and body harnesses to be interchanged since some components wear out before others. The employer and employee should realize that not all components are interchangeable.
  - Any substitution or change to a personal fall arrest system should be fully evaluated or tested by a **competent person** to determine that it meets the standard, before the modified system is put in use.
-

## COMPETENT PERSON

### §1926.503(a)(2) – Training Requirements

The employer shall assure that each employee has been trained, as necessary, by a **competent person** qualified in the following areas:

- The nature of fall hazards in the work area.
- The correct procedures for erecting, maintaining, disassembling, and inspecting the fall protection systems to be used.
- The role of employees in fall protection plans.
- OSHA fall protection standards.
- The use and operation of guardrail systems, personal fall arrest systems, safety net systems, warning line systems, safety monitoring systems, controlled access zones, and other protection to be used.
- The role of each employee in the safety monitoring system when this system is used.
- The correct procedures for the handling and storage of equipment and materials and the erection of overhead protection.



### ***“Safety Pays – Falls Cost”***

“Safety Pays – Falls Cost” is a nationwide outreach campaign to raise awareness among workers and employers about the hazards of falls from ladders, scaffolds and roofs. Visit [www.osha.gov](http://www.osha.gov) for resources, training materials and posters to display at worksites. Many of the materials target vulnerable workers with limited English proficiency.



---

Falls from ladders, scaffolds and roofs can be prevented and lives can be saved through three simple steps: **Plan, Provide** and **Train**.

---

### **PLAN** ahead to get the job done safely.

When working from heights, such as ladders, scaffolds, and roofs, employers must plan projects to ensure that the job is done safely. Begin by deciding how the job will be done, what tasks will be involved, and what safety equipment may be needed to complete each task.

When estimating the cost of a job, employers should include safety equipment, and plan to have all the necessary equipment and tools available at the construction site. For example, in a roofing job, think about all of the different fall hazards, such as holes or skylights and leading edges, then plan and select fall protection suitable to that work, such as personal fall arrest systems (PFAS).

---

### **PROVIDE** the right equipment.

Workers who are six feet or more above lower levels are at risk for serious injury or death if they should fall. To protect these workers, employers must provide fall protection and the right equipment for the job, including the right kinds of ladders, scaffolds, and safety gear.

Different ladders and scaffolds are appropriate for different jobs. Always provide workers with the kind they need to get the job done safely. For roof work, there are many ways to prevent falls. If workers use personal fall arrest systems (PFAS), provide a harness for each worker who needs to tie off to the anchor. Make sure the PFAS fits, and regularly inspect all fall protection equipment to ensure it's still in good condition and safe to use.

---

### **TRAIN** everyone to use the equipment safely.

Falls can be prevented when workers understand proper set-up and safe use of equipment, so they need training on the specific equipment they will use to complete the job. Employers must train workers in hazard recognition and in the care and safe use ladders, scaffolds, fall protection systems, and other equipment they'll be using on the job.

---

**I worked construction for 10 years  
before my fall. It shattered my body  
and my livelihood.**

**Work safely. Use the right equipment.**



Safety Pays. Falls Cost.

**FALLS FROM LADDERS, SCAFFOLDS AND ROOFS CAN BE PREVENTED!**



U.S. Department of Labor

**PLAN** ahead to get the job done safely.  
**PROVIDE** the right equipment.  
**TRAIN** everyone to use the equipment safely.  
[www.osha.gov/stopfalls/](http://www.osha.gov/stopfalls/)

1-800-321-OSHA (8742) • TTY 1-877-888-5627

**OSHA**<sup>®</sup> Occupational  
Safety and Health  
Administration  
[www.osha.gov](http://www.osha.gov)



NIOSH 2012-111 / OSHA 3531-04 2012

**Discussion Points Fall Protection Systems**

<p><b><u>Conventional fall protection systems.</u></b></p> <p>Guardrail Systems                  Safety Net Systems                  Personal Fall Arrest Systems (PFAS)                  Full Body Harness                  Lanyards                  Rope Grabs                  Shock Absorbers                  Lifelines                  Horizontal Lifeline                  Anchors                  Attaching Anchors                  Using Fall Arrest Systems Safely                  Distance of Fall                  Inspection and Maintenance of Personal                  Fall Arrest Systems                  Harness Inspection</p>	<p>Lanyard Inspection                  Shock Absorbing Packs Inspection                  Visual Indication of Damage to Webbing                  and Rope Lanyards                  Cleaning of Equipment                  Positioning Device Systems                  Restraint Systems (PFRS)                  Hole Covers</p> <p><b><u>Alternative Methods allowed by                  specific regulations.</u></b></p> <p>Warning Line Systems                  Controlled Access Zones                  Controlled Decking Zone (CDZ)                  Safety Monitoring Systems                  Fall Protection Plans</p>
---	---

Conventional fall protection systems are engineering controls that either prevent a fall from happening or protect a fallen worker from injury. Alternative Methods allowed by specific regulations are administrative controls used as part of a *Fall Protection Plan*. In some cases, the employer must prove that conventional fall protection systems are not feasible and creates greater hazards before allowing the use of a specialized fall protection system.

**NOTE:** There is a presumption that conventional fall protection systems are more often than not feasible and will not create a greater hazard. Accordingly, the employer has the burden of establishing that an alternative Methods allowed by specific regulations is appropriate.

1926.502(a) (2) Employers shall provide and install all fall protection systems required by this subpart for an employee, and shall comply with all other pertinent requirements of this subpart before that employee begins the work that necessitates the fall protection.

## **Conventional and Alternative Fall Protection Systems**

Conventional and Alternative fall protection systems may be separated into two categories:

- Active Fall protection Systems
- Passive Fall Protective Systems

The difference between the two systems is the amount of worker involvement in determining the proper installation and use of the systems. Another consideration when choosing conventional fall protection is whether the fall hazard is eliminated (fall prevention) or controlled (fall protection). A fall prevention system that limits worker involvement and eliminates the fall hazard, such as guardrails and hole covers, is the preferred method for providing worker protection against falls.

### **(Active)**

- **Personal Fall Arrest Systems (PFAS)**
- **Positioning Device Systems**
- **Restraint System**
- **Warning Line Systems**
- **Controlled Access Zones**
- **Controlled Decking Zone**
- **Safety Monitoring Systems**

### **(Passive)**

- **Safety Net Systems**
- **Protection from Falling Objects**
- **Guardrails\***
- **Hole Covers\***
- **\* Eliminates Fall Hazards**

## Guardrail Systems

“Guardrail system” means a barrier erected to prevent employees from falling to lower levels.

Guardrail systems and their use shall comply with the following provisions:

- The top edge height of toprails, or (equivalent) guardrails must be 42 inches (1.1 meters) plus or minus 3 inches (8 centimeters), above the walking/working level. When workers are using stilts, the top edge height of the top rail, or equivalent member, must be increased an amount equal to the height of the stilts.
- Screens, midrails, mesh, intermediate vertical members, or equivalent intermediate structural members must be installed between the top edge of the guardrail system and the walking/working surface when there are no walls or parapet walls at least 21 inches (53 centimeters) high.
- When midrails are used, they must be installed at a height midway between the top edge of the guardrail system and the walking/working level.
- When screens and mesh are used, they must extend from the top rail to the walking/working level and along the entire opening between top rail supports.
- Intermediate members, such as balusters, when used between posts, shall not be more than 19 inches (48 centimeters) apart.
- If wire rope is used for toprails, it must be flagged at not more 6 feet intervals (1.8 meters) with high-visibility material. Wire rope guardrails must be at least one-quarter inch (0.6 centimeters) nominal diameter or thickness to prevent cuts and lacerations.
- All guardrail systems must be smooth surfaced.

**NOTE:** Steel and plastic banding cannot be used as toprails or midrails.

**NOTE:** Manila, plastic, or synthetic rope used for toprails or midrails must be inspected as frequently as necessary to ensure strength and stability.

Screens/Mesh

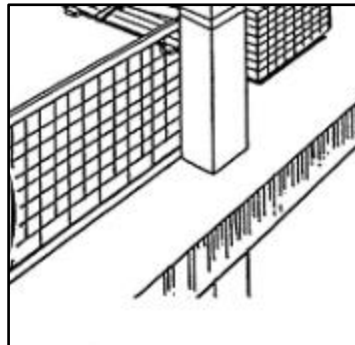

Top Rail – Mid Rail – Toe Board

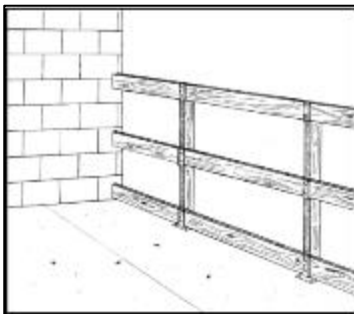

Wire Rope

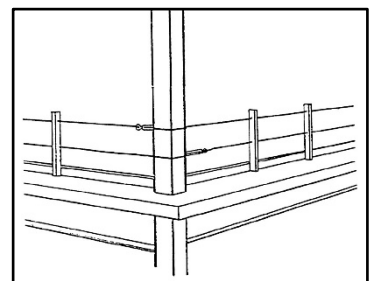

Balusters





## Guardrail Systems

Additional requirements for guardrails:

- Guardrail system must be capable of withstanding a force of at least 200 pounds (890 Newtons) applied within 2 inches of the top edge in any outward or downward direction. When the 200 pounds (890 Newtons) test is applied in a downward direction, the top edge of the guardrail must not deflect to a height less than 39 inches (1 meter) above the walking/working level.
- Midrails, screens, mesh, intermediate vertical members, solid panels, and equivalent structural members shall be capable of withstanding a force of at least 150 pounds (666 Newtons) applied in any downward or outward direction at any point along the midrail or other member.
- Toeboards shall be capable of withstanding, without failure, a force of at least 50 pounds (222 N) applied in any downward or outward direction at any point along the toeboard. "Toeboard" means a low protective barrier that will prevent the fall of materials and equipment to lower levels and provide protection from falls for personnel.

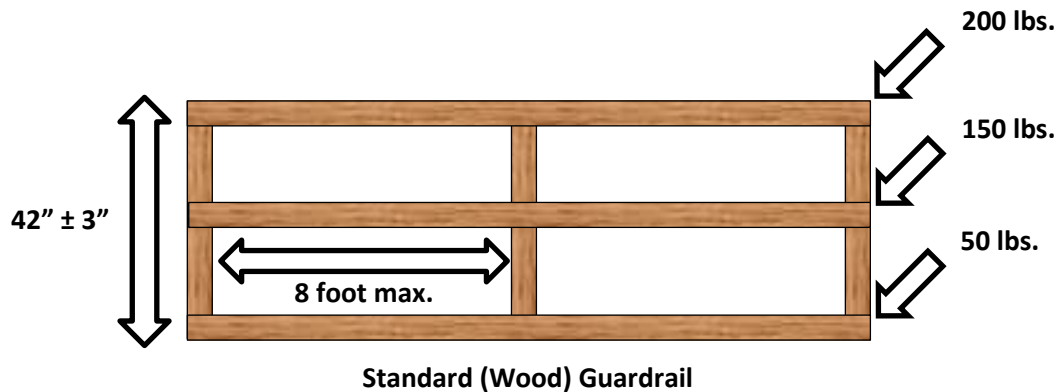

## General Guidelines

Reference: 29 CFR 1926 Subpart L (Scaffolds) – Appendix A

Guardrails shall be as follows:

**Toprails** shall be equivalent in strength to 2 inch by 4 inch lumber; or 1 ¼ inch x 1/8 inch structural angle iron; or 1 inch x .070 inch wall steel tubing; or 1.990 inch x .058 inch wall aluminum tubing.

**Midrails** shall be equivalent in strength to 1 inch by 6 inch lumber; or 1 ¼ inch x 1 ¼ inch x 1/8 inch structural angle iron; or 1 inch x .070 inch wall steel tubing; or 1.990 inch x .058 inch wall aluminum tubing.

**Toeboards** shall be equivalent in strength to 1 inch by 4 inch lumber; or 1 ¼ inch x 1 ¼ inch structural angle iron; or 1 inch x .070 inch wall steel tubing; or 1.990 inch x .058 inch wall aluminum tubing.

**Posts** shall be equivalent in strength to 2 inch by 4 inch lumber; or 1 ¼ inch x 1 ¼ inch x 1/8 inch structural angle iron; or 1 inch x .070 inch wall steel tubing; or 1.990 inch x .058 inch wall aluminum tubing. Distance between posts shall not exceed 8 feet.



## Safety Net Systems

- "Safety net systems." Safety net systems and their use shall comply with the following provisions:
- Safety nets shall be installed as close as practicable under the walking/working surface on which employees are working, but in no case more than 30 feet (9.1 m) below such level. When nets are used on bridges, the potential fall area from the walking/working surface to the net shall be unobstructed.
- Safety nets shall be installed with sufficient clearance under them to prevent contact with the surface or structures below when subjected to an impact force.
- Defective nets shall not be used. Safety nets shall be inspected at least once a week for wear, damage, and other deterioration. Defective components shall be removed from service. Safety nets shall also be inspected after any occurrence which could affect the integrity of the safety net system.
- Materials, scrap pieces, equipment, and tools which have fallen into the safety net shall be removed as soon as possible from the net and at least before the next work shift.
- The maximum size of each safety net mesh opening shall not exceed 36 square inches (230 cm) nor be longer than 6 inches (15 cm) on any side, and the opening, measured center-to-center of mesh ropes or webbing, shall not be longer than 6 inches (15 cm).
- Each safety net (or section of it) shall have a border rope for webbing with a minimum breaking strength of 5,000 pounds (22.2 kN).

Safety nets shall extend outward from the outermost projection of the work surface as follows:

Vertical distance from working level to horizontal plane of net.	Minimum required horizontal distance of outer edge of net from the edge of the working surface.
Up to 5 feet	8 feet
More than 5 feet up to 10 feet	10 feet
More than 10 feet	13 feet

**NOTE:** See 29 CFR 1926.502(c) for additional requirements on safety net systems.

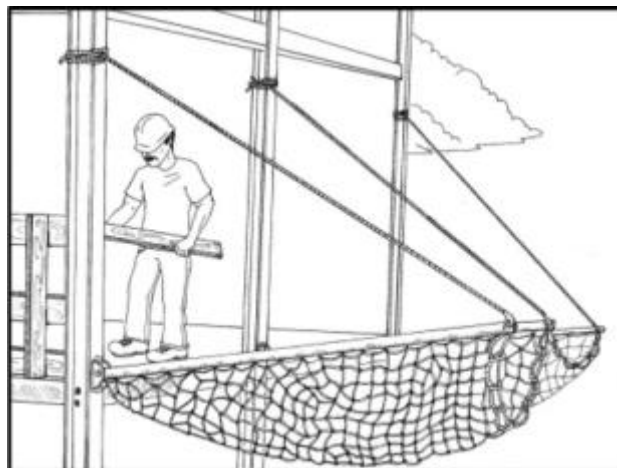

**Safety Net System**

## FALL PROTECTION SYSTEMS CRITERIA & PRACTICES

In some situations, safety nets can be placed underneath unsheathed trusses to prevent workers from falling between the trusses to the level below. Safety nets must be installed to prevent contact with the surface or structures below them. For requirements for safety nets, refer to 29 CFR 1926.502(c)-Safety Net Systems.



## Personal Fall Arrest Systems

“*Personal fall arrest system*” means a system used to arrest an employee in a fall from a working level. It consists of an anchorage, connectors, a body belt or body harness and may include a lanyard, deceleration device, lifeline, or suitable combinations of these.

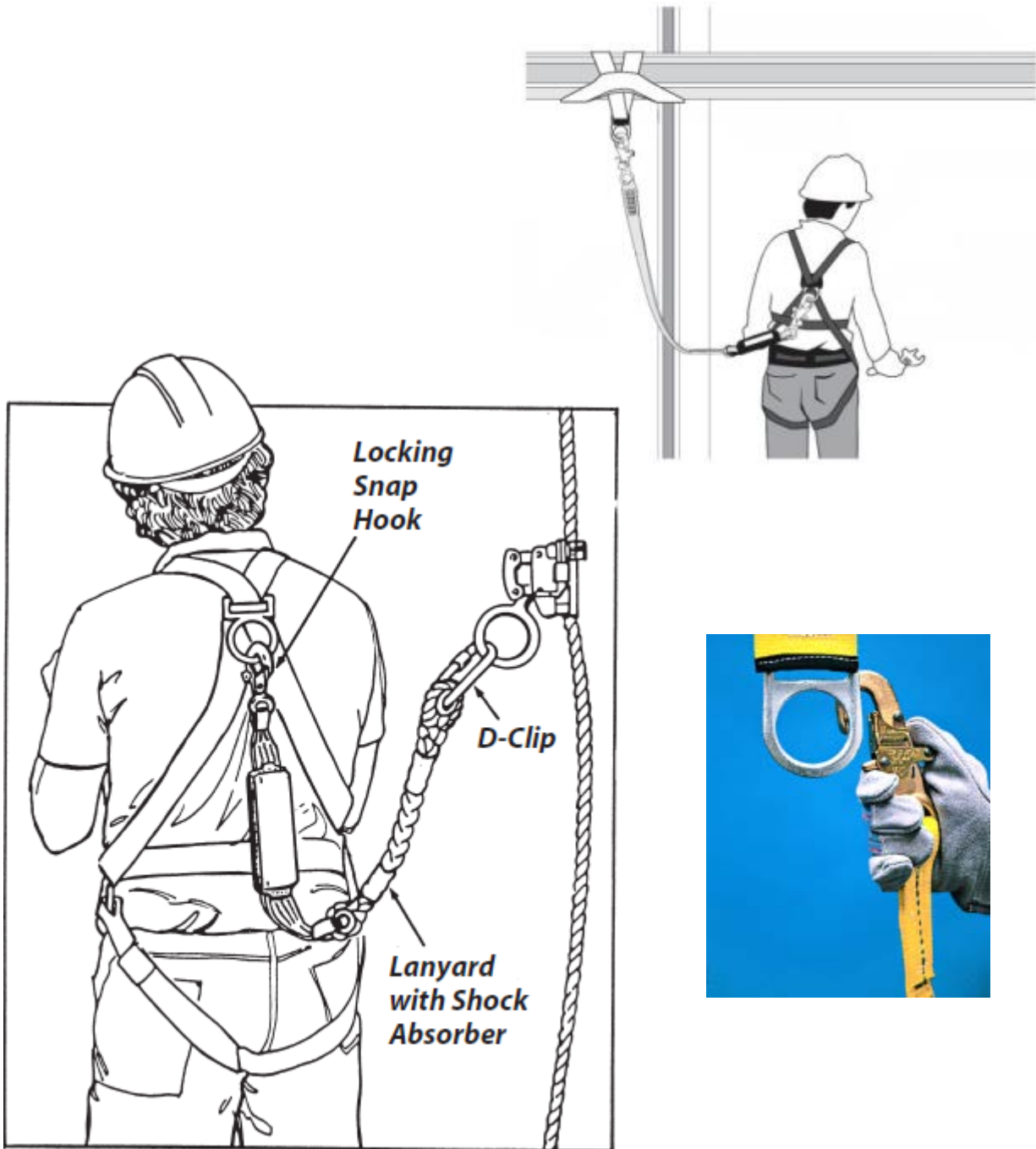

## **Full Body Harness**

A full body harness is required for fall arrest. Safety harnesses distribute fall-arrest impact through the thighs and buttocks. Safety belts (waist belts) are no longer permitted for use as personal fall arrest equipment. In a fall arrest, they can cause serious damage to internal organs such as the spleen and pancreas.



**Full Body  
Harness**

## **Lanyards**

- Lanyards connect the harness directly to an anchorage such as a rope grab or horizontal static line.
- Lanyards should be either rope or synthetic web straps specifically manufactured for such use.
- Lanyards should have spliced eyes with thimbles and be fitted with locking snap hooks or D-clips for attachment to other components (Figure 1.16).
- Lanyards with shock absorbers are strongly recommended. Never shorten a lanyard by tying knots in it. Knots seriously reduce rope strength. Also, lanyards are not to be looped over an object and then tied back to itself, unless permitted by the manufacturer.

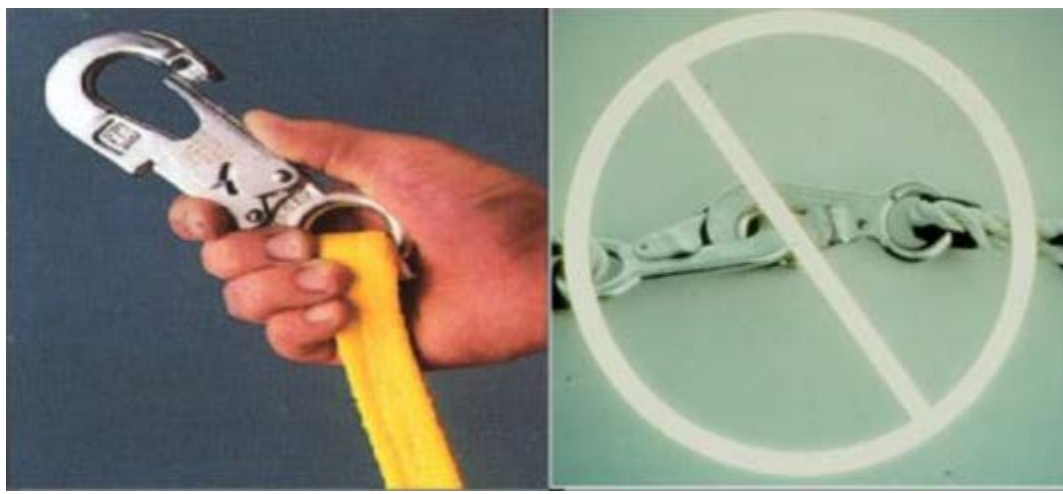



## **Rope Grabs**

Mechanical rope grabs are used to attach lanyards to vertical lifelines. Most rope grabs employ a device that locks on the lifeline when the lanyard is sharply tugged or pulled. Rope grabs must be installed in the right direction. Most grabs are marked with an arrow to indicate correct orientation.

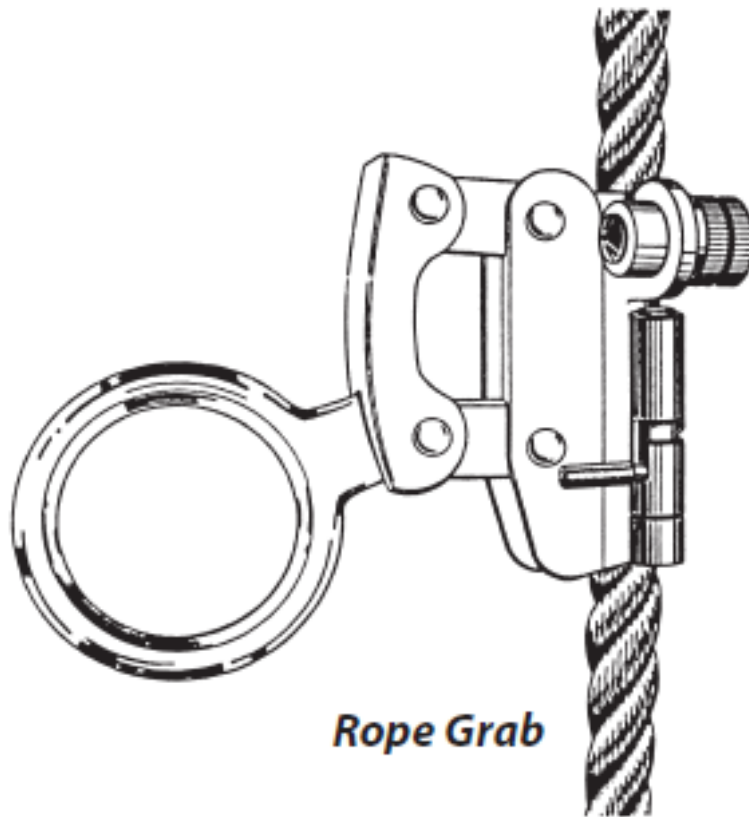

### **Shock Absorbers**

Shock absorbers are strongly recommended for use in fall-arrest systems. They are absolutely necessary with wire rope lifelines. Shock absorbers can reduce fall-arrest loads by as much as 50%

Some shock absorbers are built into the lanyard. Most are made of webbing material with tear-away stitching designed to gradually absorb a fall-arrest load.

The tear-away type also gives clear indication that fall arrest has occurred and that the system should be replaced. This results in better quality control for field equipment. Any fall arrest component involved in a fall arrest should be taken out of service to prevent reuse. It's done the job it was designed to do!



### ***Lifelines***

Vertical lifelines must be capable of sustaining a 5000 pound load used by only one worker at a time free of cuts, abrasions, and other defects protected from chafing and abrasion long enough to reach the ground (or a safe landing level above ground) and must be knotted at the bottom to prevent the grab from sliding off the end anchored to a fixed support capable of sustaining a 5000 load.

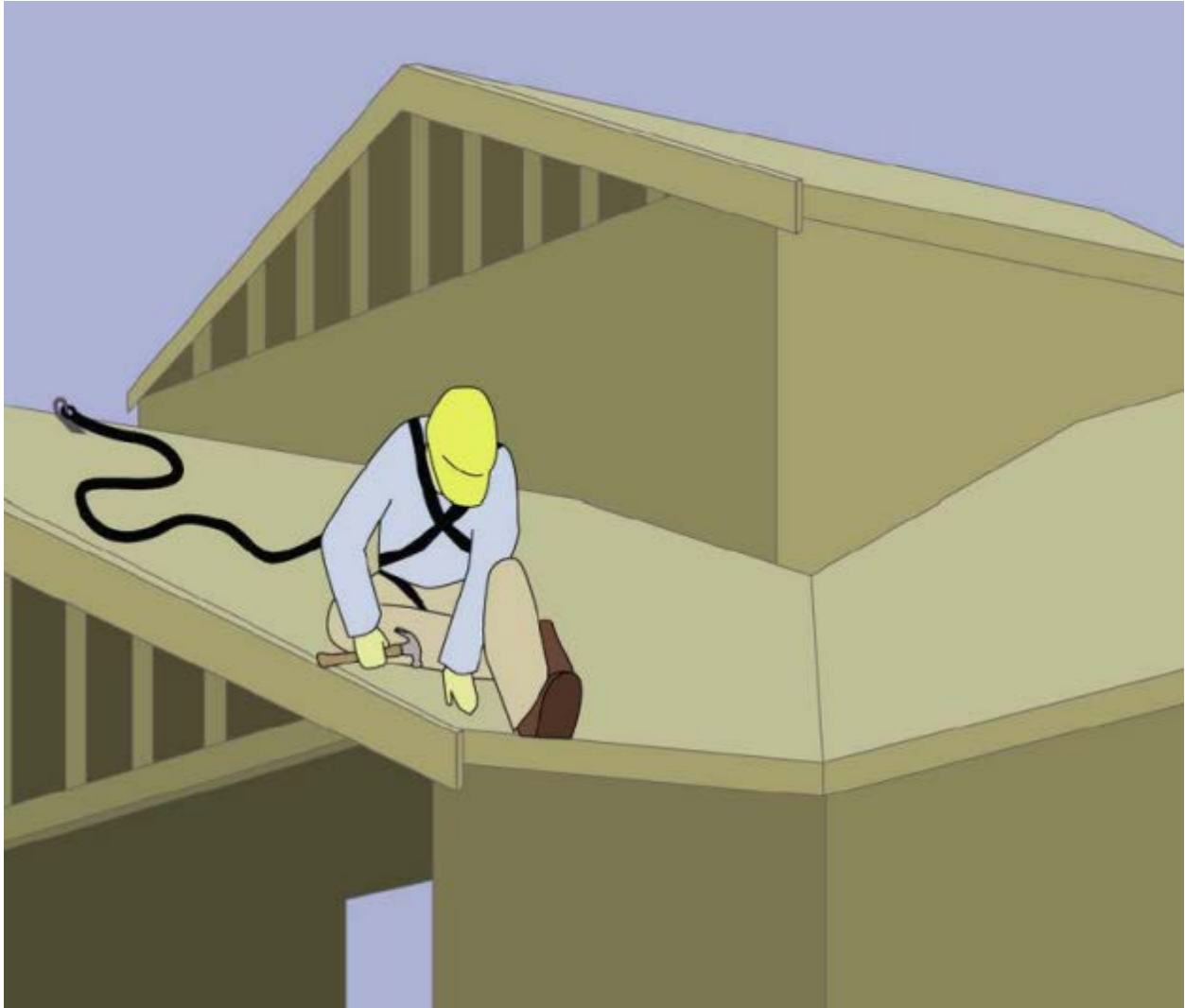

### ***Horizontal Lifeline:***

An engineered horizontal lifeline system, when used as part of a PFAS, is another way to increase the area in which a worker is protected. Install the system following the manufacturer's instructions and under the supervision of a qualified person. Horizontal lifelines must be designed to maintain a safety factor of at least two (twice the impact load). For requirements for horizontal lifelines, refer to 29 CFR 1926.502(d)(8).



**Horizontal Lifeline**



### **Lifeline Anchors**

Anchorage points should be able to support 5000 pounds. Remember: fall-arrest loads can be as high as 2000 pounds, depending on body weight and fall distance. Suitable anchorages include:

- designed systems for repair or maintenance work
- concrete or structural steel columns and beams.

Never anchor a fall arrest system to stink pipes, scupper drain covers, handrails, roof hatches, fixed ladders or stairs, vent pipes, formwork, shoring jacks, old masonry, or light structural parapets.



### **Attaching Anchors**

OSHA requires that anchors for PFAS be able to hold at least 5,000 pounds of weight per person, or maintain a safety factor of at least two (twice the impact load) under the supervision of a qualified person. Always follow the anchor manufacturer's instructions or consult a qualified person when installing anchors to ensure they are strong enough to hold the sudden weight of a falling worker. OSHA believes that anchorages available on the market will meet the strength requirements if they are installed as per the manufacturer's instructions, with the right number of properly sized nails or screws through the roof sheathing and into one or more roof trusses.

When choosing an anchor to use for fall protection, employers have a number of options; for example,

- Peak anchor: At the top of the roof, peak anchors are typically solid, non-moving pieces secured to the trusses underneath.
- Permanent D-rings: Inexpensive D-ring anchors are attached to the truss frame; they can be left permanently on the roof for future use.

---

### **Using Fall Arrest Systems Safely**

Ensure that personal fall arrest systems will, when stopping a fall:

- Limit maximum arresting force to 1,800 pounds.
- Be rigged such that an employee can neither free fall more than 6 feet nor contact any lower level.
- Bring an employee to a complete stop and limit maximum deceleration distance to 3½ feet.
- Have sufficient strength to withstand twice the potential impact energy of a worker free falling a distance of 6 feet, or the free fall distance permitted by the system, whichever is less
- Remove systems and components from service immediately if they have been subjected to fall impact, until inspected by a competent person and deemed undamaged and suitable for use.
- Promptly rescue employees in the event of a fall, or assure that they are able to rescue themselves.
- Inspect systems before each use for wear, damage, and other deterioration, and remove defective components from service.
- Do not attach fall arrest systems to guardrail systems or hoists.
- Rig fall arrest systems to allow movement of the worker only as far as the edge of the walking/working surface, when used at hoist areas.

**Distance of Fall**

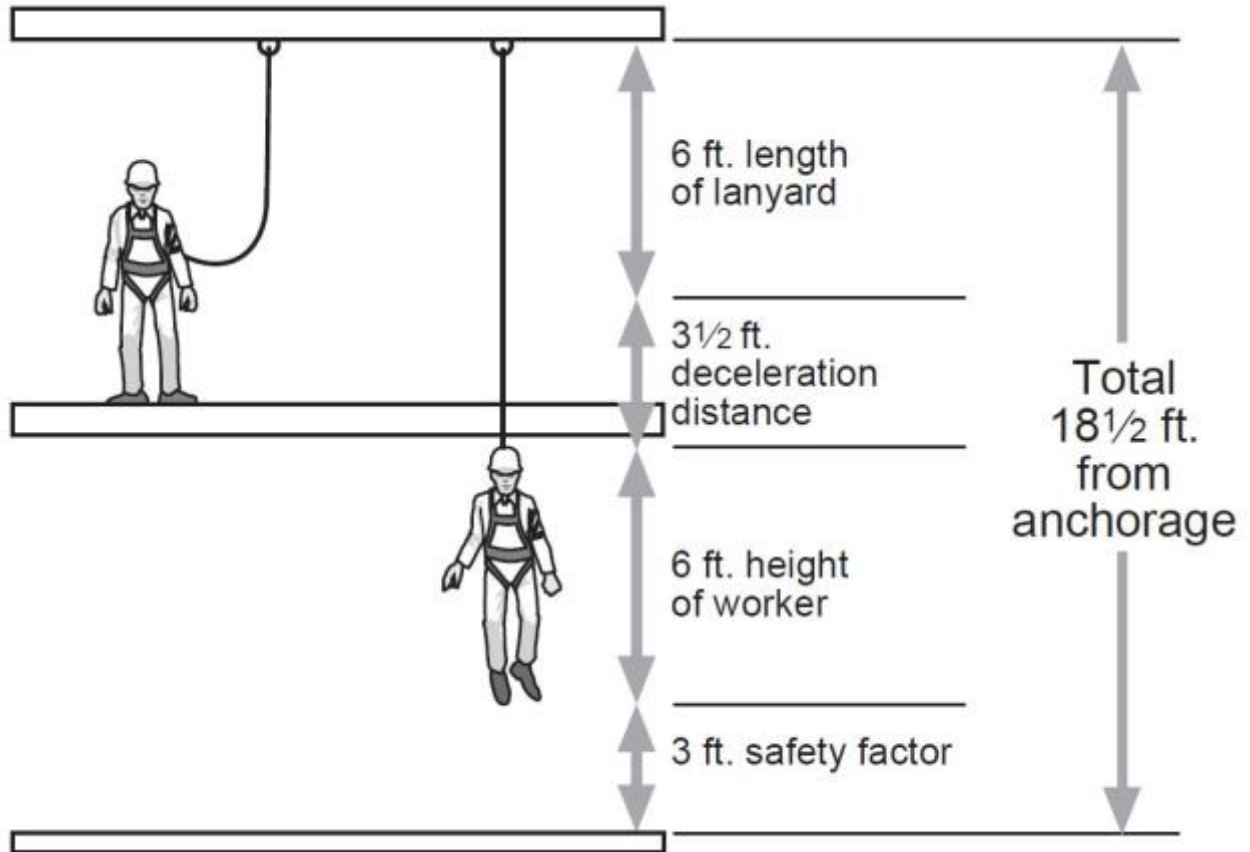

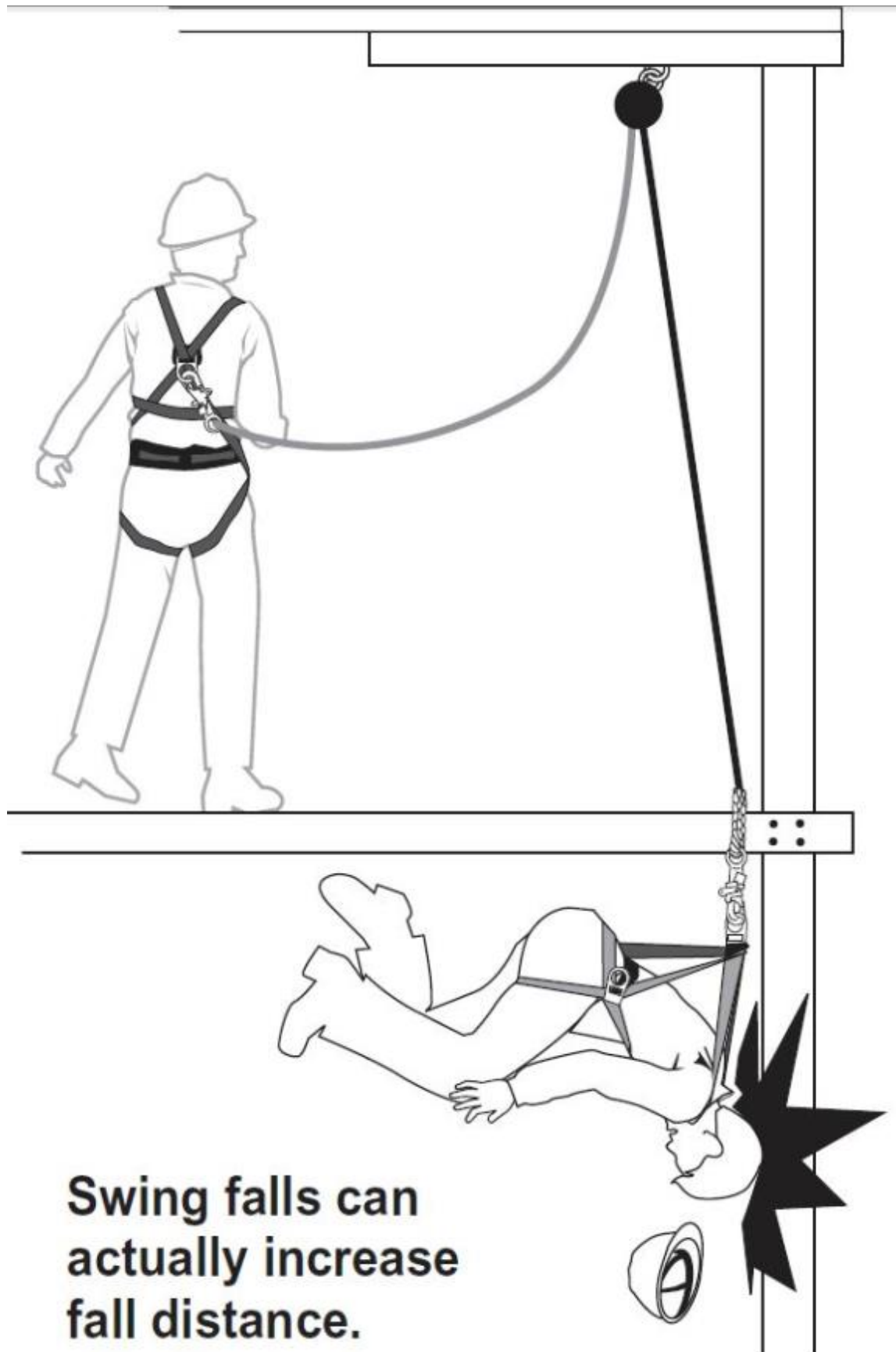

**Swing falls can  
actually increase  
fall distance.**

### Inspection and Maintenance of Personal Fall Arrest Systems

To maintain their service life and high performance, all belts and harnesses shall be inspected frequently. Visual inspection before each use is required as is a routine inspection by a competent person. If any of the conditions listed below are found the equipment shall be removed from service and replaced before being used.

---

#### *Harness Inspection*

- **Belts and Rings:** For harness inspections begin at one end, hold the body side of the belt toward you, grasping the belt with your hands six to eight inches apart. Bend the belt in an inverted "U." Watch for frayed edges, broken fibers, pulled stitches, cuts or chemical damage. Check D-rings and D-ring metal wear pads for distortion, cracks, breaks, and rough or sharp edges. The D-ring bar should be at a 90 degree angle with the long axis of the belt and should pivot freely.
- Attachments of buckles and D-rings should be given special attention. Note any unusual wear, frayed or cut fibers, or distortion of the buckles. Rivets should be tight and unremovable with fingers. Body side rivet base and outside rivets should be flat against the material. Bent rivets will fail under stress.
- Inspect frayed or broken strands. Broken webbing strands generally appear as tufts on the webbing surface. Any broken, cut or burnt stitches will be readily seen.
- **Tongue Buckle:** Buckle tongues should be free of distortion in shape and motion. They should overlap the buckle frame and move freely back and forth in their socket. Rollers should turn freely on the frame. Check for distortion or sharp edges.
- **Friction Buckle:** Inspect the buckle for distortion. The outer bar or center bars must be straight. Pay special attention to corners and attachment points of the center bar.

### **Lanyard Inspection**

When inspecting lanyards, begin at one end and work to the opposite end. Slowly rotate the lanyard so that the entire circumference is checked. Spliced ends require particular attention. Hardware should be examined under procedures detailed below.

#### **Hardware**

- **Snaps:** Inspect closely for hook and eye distortion, cracks, corrosion, or pitted surfaces. The keeper or latch should seat into the nose without binding and should not be distorted or obstructed. The keeper spring should exert sufficient force to firmly close the keeper. Keeper locks must provide the keeper from opening when the keeper closes.
- **Thimbles:** The thimble (protective plastic sleeve) must be firmly seated in the eye of the splice, and the splice should have no loose or cut strands. The edges of the thimble should be free of sharp edges, distortion, or cracks.
- **Steel Lanyards:** While rotating a steel lanyard, watch for cuts, frayed areas, or unusual wear patterns on the wire. The use of steel lanyards for fall protection without a shock-absorbing device is not recommended. Do not use steel lanyards in the presence of electrical hazards.
- **Web Lanyard:** While bending webbing over a piece of pipe, observe each side of the webbed lanyard. This will reveal any cuts or breaks. Due to the limited elasticity of the web lanyard, fall protection without the use of a shock absorber is not recommended.
- **Rope Lanyard:** Rotation of the rope lanyard while inspecting from end to end will bring to light any fuzzy, worn, broken or cut fibers. Weakened areas from extreme loads will appear as a noticeable change in original diameter. The rope diameter should be uniform throughout, following a short break-in period. When a rope lanyard is used for fall protection, a shock-absorbing system should be included.

### **Shock-Absorbing Packs Inspection**

The outer portion of the shock-absorbing pack should be examined for burn holes and tears. Stitching on areas where the pack is sewn to the D-ring, belt or lanyard should be examined for loose strands, rips and deterioration.

---

### **Visual Indication of Damage to Webbing and Rope Lanyards**

- **Heat** - In excessive heat, nylon becomes brittle and has a shriveled brownish appearance. Fibers will break when flexed and should not be used above 180 degrees Fahrenheit.
  - **Chemical** - Change in color usually appears as a brownish smear or smudge. Transverse cracks appear when belt is bent over tight. This causes a loss of elasticity in the belt.
  - **Ultraviolet Rays** - Do not store webbing and rope lanyards in direct sunlight, because ultraviolet rays can reduce the strength of some material.
  - **Molten Metal or Flame** - Webbing and rope strands may be fused together by molten metal or flame. Watch for hard, shiny spots or a hard and brittle feel. Webbing will not support combustion, nylon will.
  - **Paint and Solvents** - Paint will penetrate and dry, restricting movements of fibers. Drying agents and solvents in some paints will appear as chemical damage.
- 

### **Cleaning of Equipment**

- Basic care for fall protection safety equipment will prolong and endure the life of the equipment and contribute toward the performance of its vital safety function. Proper storage and maintenance after use is as important as cleaning the equipment of dirt, corrosives or contaminants. The storage area should be clean, dry and free of exposure to fumes or corrosive elements.
- **Nylon and Polyester** - Wipe off all surface dirt with a sponge dampened in plain water. Squeeze the sponge dry. Dip the sponge in a mild solution of water and commercial soap or detergent. Work up a thick lather with a vigorous back and forth motion. Then wipe the belt dry with a clean cloth. Hang freely to dry but away from excessive heat.
- **Drying** - Harness, belts and other equipment should be dried thoroughly without exposure to heat, steam or long periods of sunlight.

### Positioning Device Systems

This system holds the worker in place while keeping his/her hands free to work. Whenever the worker leans back, the system is activated. However, the personal positioning system is not specifically designed for fall arrest purposes. The only time a body belt may be used where there may be a fall is when an employee is using a "positioning device." In §1926.500 of the construction standards for fall protection, a "positioning device system" is defined as a body belt or body harness system rigged to allow an employee to be supported on an elevated vertical surface, such as a wall (or a pole), and work with both hands free while leaning. Therefore, in construction work, a positioning device may be used only to protect a worker on a **vertical** work surface. These devices may permit a fall of up to 2 feet (0.6 m). They may be used in concrete form work, installation of reinforcing steel, and certain telecommunications work. Since construction workers in bucket trucks, scissor lifts and boom-type elevating work platforms are on a **horizontal** surface, a positioning device may not be used for those workers.

---





**Restraint Systems**

A restraint system prevents a worker from being exposed to any fall. If the employee is protected by a restraint system, either a body belt or a harness may be used. When a restraint system is used for fall protection from an aerial lift or a boom-type elevating work platform, the employer must ensure that the lanyard and anchor are arranged so that the employee is not potentially exposed to falling any distance.

While fall restraint systems are not mentioned in OSHA’s fall protection rules, OSHA will accept a properly utilized fall restraint system in lieu of a personal fall arrest system when the restraint system is rigged so that the worker can-not get to the fall hazard. In effect, (if properly used) the system tethers a worker in a manner that will not allow a fall of any distance. A fall restraint system is comprised of a body belt or body harness, an anchorage, connectors, and other necessary equipment. Other components typically include a lanyard, and may also include a lifeline and other devices.

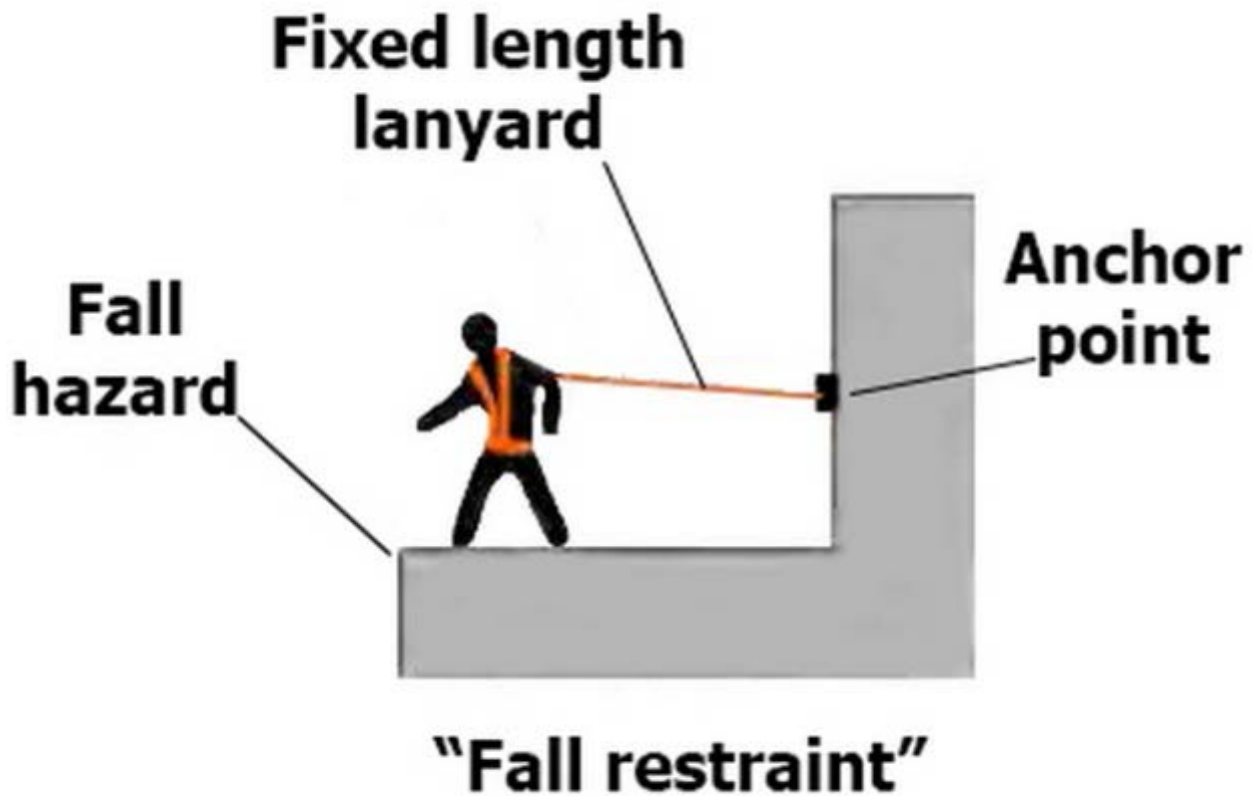

### Hole Covers

Cover or guard floor holes as soon as they are created during new construction.

For existing structures, survey the site before working and continually audit as work continues. Guard or cover any openings or holes immediately.

Construct all floor hole covers so they will effectively support two times the weight of employees, equipment, and materials that may be imposed on the cover at any one time.

Secure all floor hole covers to prevent accidental displacement by the wind, equipment, or employees.

All covers shall be color coded or they shall be marked with the word "Hole" or "Cover".

---

### Holes

"Hole" means a gap or void 2 inches (5.1 cm) or more in its least dimension, in a floor, roof, or other walking/working surface



## FALL PROTECTION SYSTEMS CRITERIA & PRACTICES



**Cover or guard floor holes as soon as they are created during new construction**

### **Walking / Working Surfaces**

Each employee on walking/working surfaces shall be protected from tripping in or stepping into or through holes (including skylights) by personal fall arrest systems, covers, or guardrail systems erected around such holes.

Employees are to also be protected from stepping in or tripping over holes where there is no hazard of falling all the way through the hole. In general as long as the opening meets the definition of a hole it must be protected

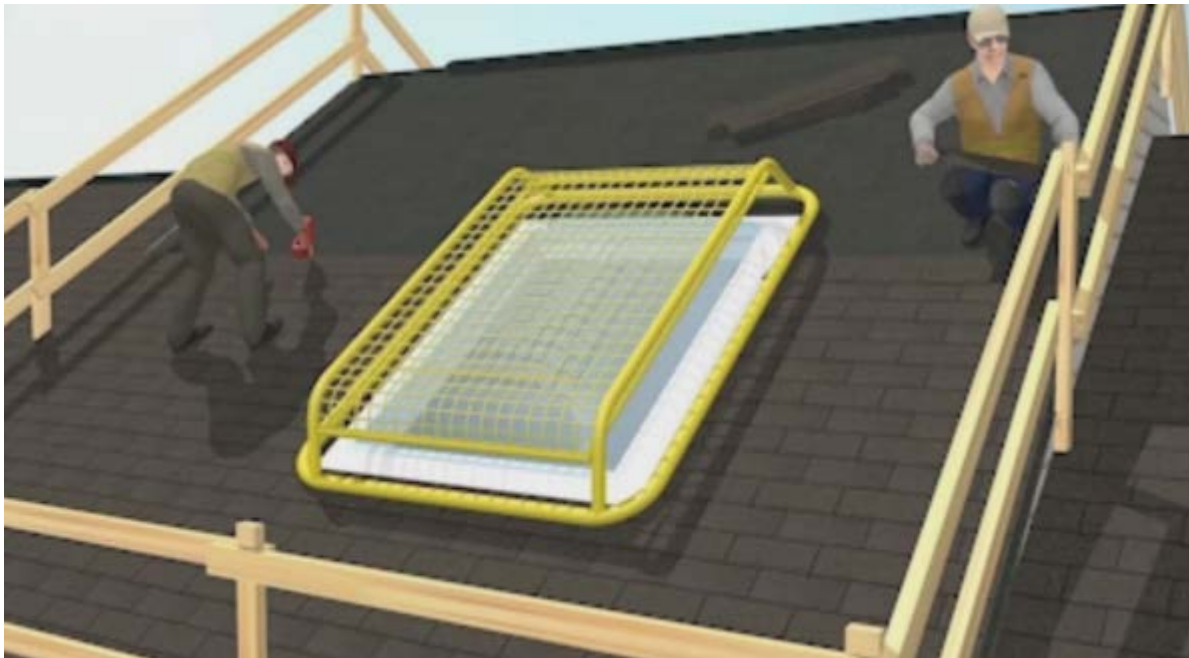

### **Protection from Falling Objects**

1926.502(j) as follows:

"Protection from falling objects." Falling object protection shall comply with the following provisions:

-Toeboards, when used as falling object protection, shall be erected along the edge of the overhead walking/working surface for a distance sufficient to protect employees below.

-Toeboards shall be capable of withstanding, without failure, a force of at least 50 pounds (222 N) applied in any downward or outward direction at any point along the toeboard.

-Toeboards shall be a minimum of 3 1/2 inches (9 cm) in vertical height from their top edge to the level of the walking/working surface. They shall have not more than 1/4 inch (0.6 cm) clearance above the walking/working surface. They shall be solid or have openings not over 1 inch (2.5 cm) in greatest dimension.

-Where tools, equipment, or materials are piled higher than the top edge of a toeboard, paneling or screening shall be erected from the walking/working surface or toeboard to the top of a guardrail system's top rail or midrail, for a distance sufficient to protect employees below.

-Guardrail systems, when used as falling object protection, shall have all openings small enough to prevent passage of potential falling objects.

-During the performance of overhand bricklaying and related work:

-No materials or equipment except masonry and mortar shall be stored within 4 feet (1.2 m) of the working edge.

-Excess mortar, broken or scattered masonry units, and all other materials and debris shall be kept clear from the work area by removal at regular intervals.

-During the performance of roofing work:

-Materials and equipment shall not be stored within 6 feet (1.8 m) of a roof edge unless guardrails are erected at the edge.

-Materials which are piled, grouped, or stacked near a roof edge shall be stable and self-supporting.

-Canopies, when used as falling object protection, shall be strong enough to prevent collapse and to prevent penetration by any objects which may fall onto the canopy.

### **Custody of Fall Protection**

Reference: 29 CFR 1926.760(e)

Fall protection provided by the steel erector shall remain in the area where steel erection activity has been completed, to be used by other trades, only if the controlling contractor or its authorized representative:

Has directed the steel erector to leave the fall protection in place; and

Has inspected and accepted control and responsibility of the fall protection prior to authorizing persons other than steel erectors to work in the area.



**Wire Rope Guardrails with Flags**

## **Warning Line Systems**

Reference 1926.502(f)

- "Warning line systems." Warning line systems [See 1926.501(b)(10)] and their use shall comply with the following provisions:
- The warning line shall be erected around all sides of the roof work area.
- When mechanical equipment is not being used, the warning line shall be erected not less than 6 feet (1.8 m) from the roof edge.
- When mechanical equipment is being used, the warning line shall be erected not less than 6 feet (1.8 m) from the roof edge which is parallel to the direction of mechanical equipment operation, and not less than 10 feet (3.1 m) from the roof edge which is perpendicular to the direction of mechanical equipment operation.
- Points of access, materials handling areas, storage areas, and hoisting areas shall be connected to the work area by an access path formed by two warning lines.
- When the path to a point of access is not in use, a rope, wire, chain, or other barricade, equivalent in strength and height to the warning line, shall be placed across the path at the point where the path intersects the warning line erected around the work area, or the path shall be offset such that a person cannot walk directly into the work area.
- Warning lines shall consist of ropes, wires, or chains, and supporting stanchions erected as follows:
- The rope, wire, or chain shall be flagged at not more than 6-foot (1.8 m) intervals with high-visibility material;
- The rope, wire, or chain shall be rigged and supported in such a way that its lowest point (including sag) is no less than 34 inches (.9 m) from the walking/working surface and its highest point is no more than 39 inches (1.0 m) from the walking/working surface;
- After being erected, with the rope, wire, or chain attached, stanchions shall be capable of resisting, without tipping over, a force of at least 16 pounds (71 N) applied horizontally against the stanchion, 30 inches (.8 m) above the walking/working surface, perpendicular to the warning line, and in the direction of the floor, roof, or platform edge;
- The rope, wire, or chain shall have a minimum tensile strength of 500 pounds (2.22 kN), and after being attached to the stanchions, shall be capable of supporting, without breaking, the loads applied to the stanchions as prescribed in paragraph (f)(2)(iii) of this section; and
- The line shall be attached at each stanchion in such a way that pulling on one section of the line between stanchions will not result in slack being taken up in adjacent sections before the stanchion tips over.
- No employee shall be allowed in the area between a roof edge and a warning line unless the employee is performing roofing work in that area.
- Mechanical equipment on roofs shall be used or stored only in areas where employees are protected by a warning line system, guardrail system, or personal fall arrest system.

## **Controlled Access Zone**

Reference 1926.502(g)

- "Controlled access zones." Controlled access zones [See 1926.501(b)(9) and 1926.502(k)] and their use shall conform to the following provisions.
- When used to control access to areas where leading edge and other operations are taking place the controlled access zone shall be defined by a control line or by any other means that restricts access.
- When control lines are used, they shall be erected not less than 6 feet (1.8 m) nor more than 25 feet (7.7 m) from the unprotected or leading edge, except when erecting precast concrete members.
- When erecting precast concrete members, the control line shall be erected not less than 6 feet (1.8 m) nor more than 60 feet (18 m) or half the length of the member being erected, whichever is less, from the leading edge.
- The control line shall extend along the entire length of the unprotected or leading edge and shall be approximately parallel to the unprotected or leading edge.
- The control line shall be connected on each side to a guardrail system or wall.
- When used to control access to areas where overhand bricklaying and related work are taking place:
  - The controlled access zone shall be defined by a control line erected not less than 10 feet (3.1 m) nor more than 15 feet (4.5 m) from the working edge.
  - The control line shall extend for a distance sufficient for the controlled access zone to enclose all employees performing overhand bricklaying and related work at the working edge and shall be approximately parallel to the working edge.
  - Additional control lines shall be erected at each end to enclose the controlled access zone.
  - Only employees engaged in overhand bricklaying or related work shall be permitted in the controlled access zone.
  - Control lines shall consist of ropes, wires, tapes, or equivalent materials, and supporting stanchions as follows:
    - Each line shall be flagged or otherwise clearly marked at not more than 6-foot (1.8 m) intervals with high-visibility material.
    - Each line shall be rigged and supported in such a way that its lowest point (including sag) is not less than 39 inches (1 m) from the walking/working surface and its highest point is not more than 45 inches (1.3 m) [50 inches (1.3 m) when overhand bricklaying operations are being performed] from the walking/working surface.
    - Each line shall have a minimum breaking strength of 200 pounds (.88 kN).
  - On floors and roofs where guardrail systems are not in place prior to the beginning of overhand bricklaying operations, controlled access zones shall be enlarged, as necessary, to enclose all points of access, material handling areas, and storage areas.
  - On floors and roofs where guardrail systems are in place, but need to be removed to allow overhand bricklaying work or leading edge work to take place, only that portion of the guardrail necessary to accomplish that day's work shall be removed.



### **Controlled Decking Zone (CDZ).**

- Reference Subpart R – Steel Erection, Controlled Decking Zone’s (CDZ) located in 1926.760(c) 1926.760(c)
- A controlled decking zone may be established in that area of the structure over 15 and up to 30 feet above a lower level where metal decking is initially being installed and forms the leading edge of a work area. In each CDZ, the following shall apply:
  - -Each employee working at the leading edge in a CDZ shall be protected from fall hazards of more than two stories or 30 feet (9.1 m), whichever is less.
  - -Access to a CDZ shall be limited to only those employees engaged in leading edge work.
  - -The boundaries of a CDZ shall be designated and clearly marked. The CDZ shall not be more than 90 feet (27.4 m) wide and 90 (27.4 m) feet deep from any leading edge. The CDZ shall be marked by the use of control lines or the equivalent. Examples of acceptable procedures for demarcating CDZ's can be found in Appendix D to this subpart.
  - -Each employee working in a CDZ shall have completed CDZ training in accordance with § 1926.761.
  - -Unsecured decking in a CDZ shall not exceed 3,000 square feet (914.4 m<sup>2</sup>).
  - -Safety deck attachments shall be performed in the CDZ from the leading edge back to the control line and shall have at least two attachments for each metal decking panel.
  - -Final deck attachments and installation of shear connectors shall not be performed in the CDZ.

### **Safety Monitoring Systems**

Reference 1926.502(h)

- "Safety monitoring systems." Safety monitoring systems [See 1926.501(b)(10) and 1926.502(k)] and their use shall comply with the following provisions:
- The employer shall designate a competent person to monitor the safety of other employees and the employer shall ensure that the safety monitor complies with the following requirements:
- The safety monitor shall be competent to recognize fall hazards;
- The safety monitor shall warn the employee when it appears that the employee is unaware of a fall hazard or is acting in an unsafe manner;
- The safety monitor shall be on the same walking/working surface and within visual sighting distance of the employee being monitored;
- The safety monitor shall be close enough to communicate orally with the employee; and
- The safety monitor shall not have other responsibilities which could take the monitor's attention from the monitoring function.
- Mechanical equipment shall not be used or stored in areas where safety monitoring systems are being used to monitor employees engaged in roofing operations on low-slope roofs.
- 1926.502(h)(3)  
No employee, other than an employee engaged in roofing work [on low-sloped roofs] or an employee covered by a fall protection plan, shall be allowed in an area where an employee is being protected by a safety monitoring system.  
Each employee working in a controlled access zone shall be directed to comply promptly with fall hazard warnings from safety monitors.

## **Fall Protection Plans**

Reference 1926.502(k)

- "Fall protection plan." This option is available only to employees engaged in leading edge work, precast concrete erection work, or residential construction work (See 1926.501(b)(2), (b)(12), and (b)(13)) who can demonstrate that it is infeasible or it creates a greater hazard to use conventional fall protection equipment. The fall protection plan must conform to the following provisions.
- The fall protection plan shall be prepared by a qualified person and developed specifically for the site where the leading edge work, precast concrete work, or residential construction work is being performed and the plan must be maintained up to date.
- Any changes to the fall protection plan shall be approved by a qualified person.
- A copy of the fall protection plan with all approved changes shall be maintained at the job site.
- The implementation of the fall protection plan shall be under the supervision of a competent person.
- The fall protection plan shall document the reasons why the use of conventional fall protection systems (guardrail systems, personal fall arrest systems, or safety nets systems) are infeasible or why their use would create a greater hazard.
- The fall protection plan shall include a written discussion of other measures that will be taken to reduce or eliminate the fall hazard for workers who cannot be provided with protection from the conventional fall protection systems. For example, the employer shall discuss the extent to which scaffolds, ladders, or vehicle mounted work platforms can be used to provide a safer working surface and thereby reduce the hazard of falling.
- The fall protection plan shall identify each location where conventional fall protection methods cannot be used. These locations shall then be classified as controlled access zones and the employer must comply with the criteria in paragraph (g) of this section.
- Where no other alternative measure has been implemented, the employer shall implement a safety monitoring system in conformance with 1926.502(h).
- The fall protection plan must include a statement which provides the name or other method of identification for each employee who is designated to work in controlled access zones. No other employees may enter controlled access zones.
- In the event an employee falls, or some other related, serious incident occurs, (e.g., a near miss) the employer shall investigate the circumstances of the fall or other incident to determine if the fall protection plan needs to be changed (e.g. new practices, procedures, or training) and shall implement those changes to prevent similar types of falls or incidents.

## DUTY TO HAVE FALL PROTECTION

### **Discussion Points**

Strength and structural integrity of walking/working surfaces  
Housekeeping  
Unprotected sides and edges  
Leading edges  
Hoist areas  
Holes (including skylights)  
Formwork and reinforcing steel  
Ramps, runways, and other walkways  
Excavations

Dangerous equipment  
Overhand bricklaying and related work  
Roofing work on low-sloped roofs  
Steep roofs  
Precast concrete erection  
Residential construction  
Wall openings  
Walking/working surfaces not otherwise addressed

### **Walking/Working Surfaces Strength and Integrity**

The employer must determine if the walking/working surfaces on which its employees are to work have the strength and structural integrity to support the employees safely. Employees must only be allowed to work on any surface only when it has been determined that it is safe to do so.

Examples of walking/working surfaces which need to be evaluated:

Roofs & Roofing Supports

Hole Covers (including Skylights)

Scaffolds & Shoring

Piping Systems

Stairways & Ladders

Formwork & Reinforcing Steel

Ramps, Runways, and other Walkways

Concrete Columns & Structures

Steel & Metal Decking

Sidewalks, Pavements, and other Appurtenant Structures

### **Housekeeping**

During the course of construction, alteration, or repairs, form and scrap lumber with protruding nails, and all other debris, shall be kept cleared from work areas, passageways, and stairs, in and around buildings or other structures.

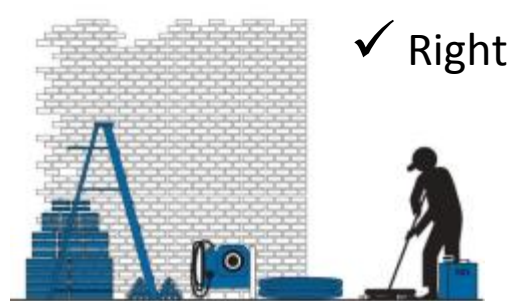

## Unprotected Sides & Edges

“Unprotected sides and edges” means any side or edge (except at entrances to points of access) of a walking/working surface, e.g., floor, roof, ramp, or runway where there is no wall or guardrail system at least 39 inches (1.0 m) high.

Each employee on a walking/working surface (horizontal and vertical surface) with an unprotected side or edge which is 6 feet (1.8 m) or more above a lower level shall be protected from falling by the use of *guardrail systems, safety net systems, or personal fall arrest systems.*

---

## Leading Edges

“Leading edge” means the edge of a floor, roof, or formwork for a floor or other walking/working surface (such as the deck) which changes location as additional floor, roof, decking, or formwork sections are placed, formed, or constructed. A leading edge is considered to be an “unprotected side and edge” during periods when it is not actively and continuously under construction.

**1926.501(b)(2)(i)** Each employee who is constructing a leading edge 6 feet (1.8 m) or more above lower levels shall be protected from falling by guardrail systems, safety net systems, or personal fall arrest systems. Exception: When the employer can demonstrate that it is infeasible or creates a greater hazard to use these systems, the employer shall develop and implement a fall protection plan which meets the requirements of paragraph (k) of 1926.502.

---

## Hoist Areas

**1926.501(b)(3)** Hoist areas." Each employee in a hoist area shall be protected from falling 6 feet (1.8 m) or more to lower levels by guardrail systems or personal fall arrest systems. If guardrail systems, [or chain, gate, or guardrail] or portions thereof, are removed to facilitate the hoisting operation (e.g., during landing of materials), and an employee must lean through the access opening or out over the edge of the access opening (to receive or guide equipment and materials, for example), that employee shall be protected from fall hazards by a personal fall arrest system.

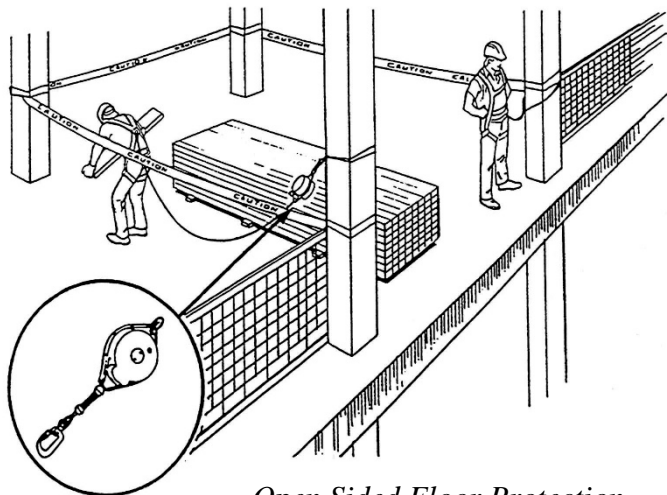

## Holes

"Hole" means a gap or void 2 inches (5.1 cm) or more in its least dimension, in a floor, roof, or other walking/working surface.

---

## Formwork & Reinforcing Steel

"Formwork" means the total system of support for freshly placed or partially cured concrete, including the mold or sheeting (form) that is in contact with the concrete as well as all supporting members including shores, reshores, hardware, braces, and related hardware.

"Formwork and reinforcing steel." Each employee on the face of formwork or reinforcing steel shall be protected from falling 6 feet (1.8 m) or more to lower levels by personal fall arrest systems, safety net systems, or positioning device systems.



## Ramps, Runways/Walkways

"Ramps" means an inclined walking or working surface that is used to gain access to one point from another.

"Runways/Walkways" means a portion of an elevated platform used only for access and not as a work level.

1926.451(e)(5)(i) Ramps and walkways 6 feet (1.8 m) or more above lower levels shall have guardrail systems which comply with subpart M of this part -- Fall Protection;

1926.451(e)(5)(ii) No ramp or walkway shall be inclined more than a slope of one (1) vertical to three (3) horizontal (20 degrees above the horizontal).

1926.451(e)(5)(iii) If the slope of a ramp or a walkway is steeper than one (1) vertical in eight (8) horizontal, the ramp or walkway shall have cleats not more than fourteen (14) inches (35 cm) apart which are securely fastened to the planks to provide footing.

1926.501(b)(6) "Ramps, runways, and other walkways." Each employee on ramps, runways, and other walkways shall be protected from falling 6 feet (1.8 m) or more to lower levels by guardrail systems.

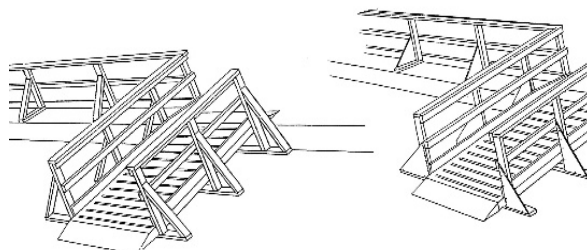

## DUTY TO HAVE FALL PROTECTION

### **Excavations**

“*Excavation*” means any man-made cut, cavity, trench, or depression in an earth surface, formed by earth removal.

“*Trench*” (Trench excavation)” means a narrow excavation (in relation to its length) made below the surface of the ground. In general, the depth is greater than the width, but the width of a trench (measured at the bottom) is not greater than 15 feet (4.6 m). If forms or other structures are installed or constructed in an excavation so as to reduce the dimension measured from the forms or structure to the side of the excavation to 15 feet (4.6 m) or less (measured at the bottom of the excavation), the excavation is also considered to be a trench.

Walkways shall be provided where employee or equipment required or permitted to cross over excavations. Guardrails which comply with 29 CFR 1926.502(b) shall be provided where walkways are 6 feet or more above lower levels.

**1926.501(b)(7)(i)** Each employee at the edge of an excavation 6 feet (1.8 m) or more in depth shall be protected from falling by guardrail systems, fences, or barricades when the excavations are not readily seen because of plant growth or other visual barrier; **1926.501(b)(7)(ii)** Each employee at the edge of a well, pit, shaft, and similar excavation 6 feet (1.8 m) or more in depth shall be protected from falling by guardrail systems, fences, barricades, or covers.

---

### **Dangerous Equipment**

“*Dangerous equipment*” means equipment (such as pickling or galvanizing tanks, degreasing units, machinery, electrical equipment, and other units) which, as a result of form or function, may be hazardous to employees who fall onto or into such equipment.

Regardless of height, if a worker can fall into or onto dangerous machines or equipment (such as a vat or acid or a conveyor belt) employers must provide guardrails and toe-boards to prevent workers from falling and getting injured.

### **Overhand Bricklaying**

*“Overhand bricklaying and related work”* means the process of laying bricks and masonry units such that the surface of the wall to be jointed is on the opposite side of the wall from the mason, requiring the mason to lean over the wall to complete the work. Related work includes mason tending and electrical installation incorporated into the brick wall during the overhand bricklaying process.

Where a mason performs overhand bricklaying and related work 6 feet above lower levels, the requirements for fall protection systems can be satisfied by the use of guardrail systems, safety net systems, personal fall arrest systems, or by creating a controlled access zone in which only employees engaged in overhand bricklaying or related work, works. However controlled access zones are not permitted where the mason is reaching more than 10 inches below the level of the walking/working surface on which he is working. In that instance conventional fall protection such as a guardrail system, safety net system, or personal fall arrest system is required to be used.

---

### **Roofing Work on Low-sloped Roofs**

*“Roofing work”* means the hoisting, storage, application, and removal of roofing materials and equipment, including related insulation, sheet metal, and vapor barrier work, but not including the construction of the roof deck.

*“Low-slope roof”* means a roof having a slope less than or equal to 4 in 12 (vertical to horizontal).

29 CFR 1926 (b)(10) Roofing work on Low-slope roofs. Except as otherwise provided in paragraph (b) of this section, each employee engaged in roofing activities on low-slope roofs, with unprotected sides and edges 6 feet (1.8 m) or more above lower levels shall be protected from falling by guardrail systems, safety net systems, personal fall arrest systems, or a combination of warning line system and guardrail system, warning line system and safety net system, or warning line system and personal fall arrest system, or warning line system and safety monitoring system. Or, on roofs 50-feet (15.25 m) or less in width (see appendix A to subpart M of this part), the use of a safety monitoring system alone [i.e. without the warning line system] is permitted.

### **Steep Roofs**

*“Steep roof”* means a roof having a slope greater than 4 in 12 (vertical to horizontal).

1926.501(b)(11) "Steep roofs." Each employee on a steep roof with unprotected sides and edges 6 feet (1.8 m) or more above lower levels shall be protected from falling by guardrail systems with toeboards, safety net systems, or personal fall arrest systems.





### **Precast Concrete Erection**

*"Precast concrete"* means concrete members (such as walls, panels, slabs, columns, and beams) which have been formed, cast, and cured prior to final placement in a structure.

1926.501(b)(12) "Precast concrete erection." Each employee engaged in the erection of precast concrete members (including, but not limited to the erection of wall panels, columns, beams, and floor and roof "tees") and related operations such as grouting of precast concrete members, who is 6 feet (1.8 m) or more above lower levels shall be protected from falling by guardrail systems, safety net systems, or personal fall arrest systems, unless another provision in paragraph (b) of this section provides for an alternative fall protection measure. Exception: When the employer can demonstrate that it is infeasible or creates a greater hazard to use these systems, the employer shall develop and implement a fall protection plan which meets the requirements of paragraph (k) of 1926.502.

Note: There is a presumption that it is feasible and will not create a greater hazard to implement at least one of the above-listed fall protection systems. Accordingly, the employer has the burden of establishing that it is appropriate to implement a fall protection plan which complies with 1926.502(k) for a particular workplace situation, in lieu of implementing any of those systems.

### **Residential Construction**

OSHA's interpretation of residential combines two elements, both of which must be satisfied for a project to fall under the definition of "residential construction".

The end-use of the structure being built must be as a home, i.e., a dwelling, and;

The structure being built must be constructed using traditional wood frame construction materials and methods.

Traditional wood frame construction materials and methods will be characterized by

Framing materials: Wood (or equivalent cold-formed sheet metal stud) framing, not steel or concrete; wooden floor joists and roof structures.

Exterior wall structure: Wood (or equivalent cold-formed sheet metal stud) framing or masonry brick or block.

Methods: Traditional wood frame construction techniques.

*NOTE:* The limited use of structural steel in a predominantly wood-frame home, such as a steel I-beam to help support wood framing, does not disqualify a structure from being considered residential construction.

Employees working six (6) feet or more above lower levels must be protected by conventional fall protection methods listed in 1926.501(b)(13) ( i.e., guardrail systems, safety net systems, or personal fall arrest systems ) or alternative fall protection measures allowed by other provisions of 29 CFR 1926.501(b) for particular types of work.

An example of an alternative fall protection measure allowed under 1926.501(b) is the use of warning lines and safety monitoring systems during the performance of roofing work on low-sloped roofs. (4 in 12 pitch or less). (See 1926.501(b)(10)).

OSHA allows the use of an effective fall restraint system in lieu of a personal fall arrest system. To be effective, a fall restraint system must be rigged to prevent a worker from reaching a fall hazard and falling over the edge. A fall restraint system may consist of a full body harness or body belt that is connected to an anchor point at the center of a roof by a lanyard of a length that will not allow a worker to physically reach the edge of the roof.

When the employer can demonstrate that it is infeasible or creates a greater hazard to use required fall protection systems, a qualified person must develop a written site-specific fall protection plan in accordance with 1926.502(k) that, among other things, specifies the alternative fall protection methods that will be used to protect workers from falls.

### **Wall Openings**

*“Wall openings”* are where the outside bottom edge of the wall opening is 6 feet (1.8 m) or more above lower levels and the inside bottom edge of the wall opening is less than 39 inches (1.0 m) above the walking/working surface.

29 CFR 1926 (b)(14) Wall openings. Each employee working on, at, above, or near wall openings (including those with chutes attached) where the outside bottom edge of the wall opening is 6 feet (1.8 m) or more above lower levels and the inside bottom edge of the wall opening is less than 39 inches (1.0 m) above the walking/working surface, shall be protected from falling by the use of a guardrail system, a safety net system, or a personal fall arrest system.

---

### **Walking/Working Surfaces not otherwise Addressed**

*“Walking/working surface”* means any surface, whether horizontal or vertical on which an employee walks or works, including, but not limited to, floors, roofs, ramps, bridges, runways, formwork and concrete reinforcing steel but not including ladders, vehicles, or trailers, on which employees must be located in order to perform their job duties.

29 CFR 1926 (b)(15) Walking/working surfaces not otherwise addressed. Except as provided in §1926.500(a)(2) or in §1926.501 (b)(1) through (b)(14), each employee on a walking/working surface 6 feet (1.8 m) or more above lower levels shall be protected from falling by a guardrail system, safety net system, or personal fall arrest system.

## **Introduction Stairs and Ladders**

Working on and around stairways and ladders is hazardous. Stairways and ladders are major sources of injuries and fatalities among construction workers for example, and many of the injuries are serious enough to require time off the job. OSHA rules apply to all stairways and ladders used in construction, alteration, repair, painting, decorating and demolition of worksites covered by OSHA's construction safety and health standards.

---

## **General Requirements**

These rules specify when employers must provide stairways and ladders. In general, the standards require the following:

When there is a break in elevation of 19 inches (48 cm) or more and no ramp, runway, embankment or personnel hoist is available, employers must provide a stairway or ladder at all worker points of access. When there is only one point of access between levels, employers must keep it clear of obstacles to permit free passage by workers. If free passage becomes restricted, employers must provide a second point of access and ensure that workers use it.

When there are more than two points of access between levels, employers must ensure that at least one point of access remains clear. In addition, employers must install all stairway and ladder fall protection systems required by these rules and ensure that their worksite meets all requirements of the stairway and ladder rules before employees use stairways or ladders. See 29 CFR 1926.1050-1060 for the details of the standard.

Note: The standard does not apply to ladders specifically manufactured for scaffold access and egress, but does apply to job-made and manufactured portable ladders intended for general purpose use. Rules for ladders used on or with scaffolds are addressed in 29 CFR 1926.451 Subpart L.

## Rules for Ladders

### All Ladders

The following rules apply to all ladders:

Maintain ladders free of oil, grease and other slipping hazards.

Do not load ladders beyond their maximum intended load nor beyond their manufacturer's rated capacity.

Use ladders only for their designed purpose.

Use ladders only on stable and level surfaces unless secured to prevent accidental movement.

Do not use ladders on slippery surfaces unless secured or provided with slip-resistant feet to prevent accidental movement. Do not use slip resistant feet as a substitute for exercising care when placing, lashing or holding a ladder upon slippery surfaces.

Secure ladders placed in areas such as passageways, doorways or driveways, or where they can be displaced by workplace activities or traffic to prevent accidental movement. Or use a barricade to keep traffic or activity away from the ladder.

Keep areas clear around the top and bottom of ladders.

Do not move, shift or extend ladders while in use.

Use ladders equipped with nonconductive side rails if the worker or the ladder could contact exposed energized electrical equipment.

Face the ladder when moving up or down.

Use at least one hand to grasp the ladder when climbing.

Do not carry objects or loads that could cause loss of balance and falling.

In addition, the following general requirements apply to all ladders, including ladders built at the jobsite:

Double-cleated ladders or two or more ladders must be provided when ladders are the only way to enter or exit a work area where 25 or more employees work or when a ladder serves simultaneous two-way traffic.

Ladder rungs, cleats and steps must be parallel, level and uniformly spaced when the ladder is in position for use.

Rungs, cleats and steps of portable and fixed ladders (except as provided below) must not be spaced less than 10 inches (25 cm) apart, nor more than 14 inches (36 cm) apart, along the ladder's side rails.

Rungs, cleats and steps of step stools must not be less than 8 inches (20 cm) apart, nor more than 12 inches (31 cm) apart, between center lines of the rungs, cleats and steps.

Rungs, cleats and steps at the base section of extension trestle ladders must not be less than 8 inches (20 cm) nor more than 18 inches (46 cm) apart, between center lines of the rungs, cleats and steps. The rung spacing on the extension section must not be less than 6 inches (15 cm) nor more than 12 inches (31 cm).

Ladders must not be tied or fastened together to create longer sections unless they are specifically designed for such use.

When splicing side rails, the resulting side rail must be equivalent in strength to a one-piece side rail made of the same material.

Two or more separate ladders used to reach an elevated work area must be offset with a platform or landing between the ladders, except when portable ladders are used to gain access to fixed ladders.

Ladder components must be surfaced to prevent snagging of clothing and injury from punctures or lacerations.

Wood ladders must not be coated with any opaque covering except for identification or warning labels, which may be placed only on one face of a side rail.

Note: A competent person must inspect ladders for visible defects periodically and after any incident that could affect their safe use.

# LADDERS

## Specific Types of Ladders

Do not use single-rail ladders.

Use non-self-supporting ladders at an angle where the horizontal distance from the top support to the foot of the ladder is approximately one-quarter of the working length of the ladder.

Use wooden ladders built at the jobsite with spliced side rails at an angle where the horizontal distance is one-eighth of the working length of the ladder.

In addition, the top of a non-self-supporting ladder must be placed with two rails supported equally unless it is equipped with a single support attachment.

---

## Stepladders

Do not use the top or top step of a stepladder as a step.

Do not use cross bracing on the rear section of stepladders for climbing unless the ladders are designed and provided with steps for climbing on both front and rear sections.

Metal spreader or locking devices must be provided on stepladders to hold the front and back sections in an open position when ladders are being used.

---

## Portable Ladders

The minimum clear distance between side rails for all portable ladders must be at least 3 feet (91 cm) above the intended load; extra heavy-duty type 1A metal or plastic ladders must be at least 3 feet (91 cm) above the intended load. In addition, the rungs and steps of portable metal ladders must be made of skid-resistant material or treated to minimize slipping.

Non-self-supporting and self-supporting portable ladders must be used at an angle of 75 degrees to the intended load; extra heavy-duty type 1A metal or plastic ladders must be used at an angle of 75 degrees to the intended load. To determine whether a self-supporting ladder is being used at the correct angle, the ladder must be extended to the ladder in a downward vertical direction with the ladder at the intended angle.

When portable ladders are used for access to an upper landing, the ladder must be secured and a grasping device such as a grab rail must be provided. The ladder must be mounted and dismounted at the upper landing. A ladder extension must be used to prevent the ladder from slipping off its supports.

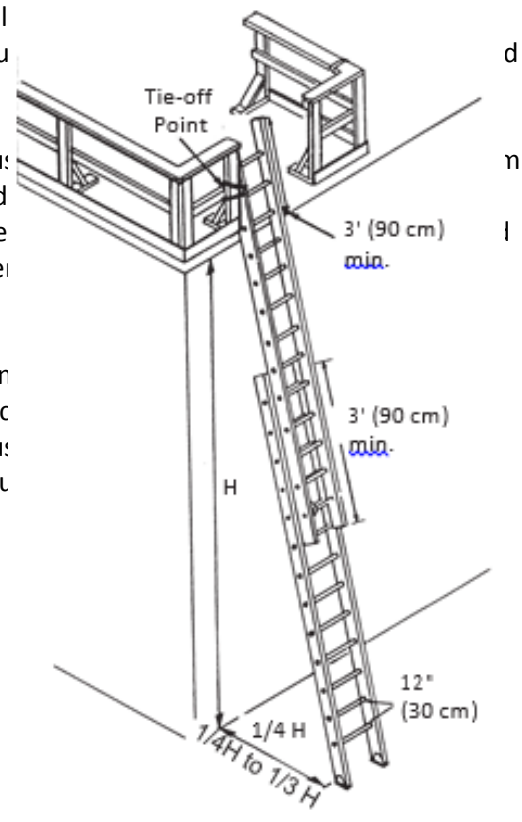

# 7 Steps to Ladder Safety

## 7 PASOS DE SEGURIDAD EN ESCALERAS

**1** Extend ladder 3' above the surface  
*Extienda la escalera 3 pies por encima del punto que desee alcanzar*

3'

**2** Tie off ladder at top  
*Asegure la escalera en la parte de arriba para que no se resbale*

**3** 3-point contact at all times when climbing ladder  
*Mantenga dos manos y un pie o una mano y dos pies en la escalera todo el tiempo*

**4** Don't use if ladder has broken rungs  
*No use la escalera si esta dañada o defectuosa*

**5** For every 4' in height, put ladder 1' back  
*Coloque la escalera en ángulo para que la base quede a 1 pie de distancia del lugar donde esté apoyada por cada 4 pies de altura*

1'  
4'

**6** Secure ladder at bottom  
*Asegure la escalera en la base*

**7** Never carry tools or materials on ladder  
*Nunca cargue materiales o equipos mientras suba o descienda. Use un montacargas o una polea*

## LADDERS

### **Fixed Ladders**

If the total length of the climb on a fixed ladder equals or exceeds 24 feet (7.3 m), the ladder must be equipped with ladder safety devices; or self-retracting lifelines and rest platforms at intervals not to exceed 150 feet (45.7 m); or a cage or well and multiple ladder sections with each ladder section not to exceed 50 feet (15.2 m) in length. These ladder sections must be offset from adjacent sections and landing platforms must be provided at maximum intervals of 50 feet (15.2 m). In addition, fixed ladders must meet the following requirements:

Fixed ladders must be able to support at least two loads of 250 pounds (114 kg) each, concentrated between any two consecutive attachments. Fixed ladders also must support added anticipated loads caused by ice buildup, winds, rigging and impact loads resulting from using ladder safety devices. Individual rung/step ladders must extend at least 42 inches (1.1 m) above an access level or landing platform either by the continuation of the rung spacings as horizontal grab bars or by providing vertical grab bars that must have the same lateral spacing as the vertical legs of the ladder rails.

Each step or rung of a fixed ladder must be able to support a load of at least 250 pounds (114 kg) applied in the middle of the step or rung.

Minimum clear distance between the sides of individual rung/step ladders and between the side rails of other fixed ladders must be 16 inches (41 cm).

Rungs of individual rung/step ladders must be shaped to prevent slipping off the end of the rungs.

Rungs and steps of fixed metal ladders manufactured after March 15, 1991, must be corrugated, knurled, dimpled, coated with skid-resistant material or treated to minimize slipping.

Minimum perpendicular clearance between fixed ladder rungs, cleats, and steps and any obstruction behind the ladder must be 7 inches (18 cm), except that the clearance for an elevator pit ladder must be 4.5 inches (11 cm).

Minimum perpendicular clearance between the centerline of fixed ladder rungs, cleats and steps, and any obstruction on the climbing side of the ladder must be 30 inches (76 cm). If obstructions are unavoidable, clearance may be reduced to 24 inches (61 cm), provided a deflection device is installed to guide workers around the obstruction.

Step-across distance between the center of the steps or rungs of fixed ladders and the nearest edge of a landing area must be no less than 7 inches (18 cm) and no more than 12 inches (30 cm). A landing platform must be provided if the step-across distance exceeds 12 inches (30 cm).

Fixed ladders without cages or wells must have at least a 15-inch (38 cm) clearance width to the nearest permanent object on each side of the centerline of the ladder.

Fixed ladders must be provided with cages, wells, ladder safety devices or self-retracting lifelines where the length of climb is less than 24 feet (7.3 m) but the top of the ladder is at a distance greater than 24 feet (7.3 m) above lower levels.

Side rails of through or side-step fixed ladders must extend 42 inches (1.1 m) above the top level or landing platform served by the ladder. Parapet ladders must have an access level at the roof if the parapet is cut to permit passage through it. If the parapet is continuous, the access level is the top of the parapet.

Steps or rungs for through-fixed-ladder extensions must be omitted from the extension; and the extension of side rails must be flared to provide between 24 inches (61 cm) and 30 inches (76 cm) clearance between side rails.

When safety devices are provided, the maximum clearance distance between side rail extensions must not exceed 36 inches (91 cm).

Fixed ladders must be used at a pitch no greater than 90 degrees from the horizontal, measured from the back side of the ladder.



## **Cages for Fixed Ladders**

The requirements for cages for fixed ladders are as follows:

Horizontal bands must be fastened to the side rails of rail ladders or directly to the structure, building or equipment for individual-rung ladders. Vertical bars must be on the inside of the horizontal bands and must be fastened to them.

Cages must not extend less than 27 inches (68 cm), or more than 30 inches (76 cm) from the centerline of the step or rung and must not be less than 27 inches (68 cm) wide.

Insides of cages must be clear of projections.

Horizontal bands must be spaced at intervals not more than 4 feet (1.2 m) apart measured from centerline to centerline.

Vertical bars must be spaced at intervals not more than 9.5 inches (24 cm), measured centerline to centerline.

Bottoms of cages must be between 7 feet (2.1 m) and 8 feet (2.4 m) above the point of access to the bottom of the ladder. The bottom of the cage must be flared not less than 4 inches (10 cm) between the bottom horizontal band and the next higher band.

Tops of cages must be a minimum of 42 inches (1.1 m) above the top of the platform or the point of access at the top of the ladder. There must be a way to access the platform or other point of access.

---

## **Wells for Fixed Ladders**

The requirements for wells for fixed ladders are as follows:

Wells must completely encircle the ladder.

Wells must be free of projections.

Inside faces of wells on the climbing side of the ladder must extend between 27 inches (68 cm) and 30 inches (76 cm) from the centerline of the step or rung.

Inside widths of wells must be at least 30 inches (76 cm).

Bottoms of wells above the point of access to the bottom of the ladder must be between 7 feet (2.1 m) and 8 feet (2.4 m).

---

## **Ladder Safety Devices and Related Support Systems for Fixed Ladders**

The connection between the carrier or lifeline and the point of attachment to the body belt or harness must not exceed 9 inches (23 cm) in length. In addition, ladder safety devices and related support systems on fixed ladders must conform to the following:

All safety devices must be able to withstand, without failure, a drop test consisting of a 500-pound weight (226 kg) dropping 18 inches (41 cm).

All safety devices must permit the worker to ascend or descend without continually having to hold, push or pull any part of the device, leaving both hands free for climbing.

All safety devices must be activated within 2 feet (.61 m) after a fall occurs and limit the descending velocity of an employee to 7 feet/second (2.1 m/sec) or less.

### **Requirements for Mounting Ladder Safety Devices for Fixed Ladders**

The requirements for mounting ladder safety devices for fixed ladders are as follows:

Mountings for rigid carriers must be attached at each end of the carrier, with intermediate mountings spaced along the entire length of the carrier, to provide the necessary strength to stop workers' falls.

Mountings for flexible carriers must be attached at each end of the carrier. Cable guides for flexible carriers must be installed with a spacing between 25 feet (7.6 m) and 40 feet (12.2 m) along the entire length of the carrier, to prevent wind damage to the system.

Design and installation of mountings and cable guides must not reduce the strength of the ladder.

Side rails and steps or rungs for side-step fixed ladders must be continuous in extension.

---

### **Defective Ladders**

Ladders needing repairs are subject to the following rules:

Portable ladders with structural defects—such as broken or missing rungs, cleats or steps, broken or split rails, corroded components or other faulty or defective components—must immediately be marked defective or tagged with "Do Not Use" or similar language and withdrawn from service until repaired.

Fixed ladders with structural defects—such as broken or missing rungs, cleats or steps, broken or split rails or corroded components— must be withdrawn from service until repaired.

Defective fixed ladders are considered withdrawn from use when they are immediately tagged with "Do Not Use" or similar language, or marked in a manner that identifies them as defective, or blocked—such as with a plywood attachment that spans several rungs.

Ladder repairs must restore the ladder to a condition meeting its original design criteria before the ladder is returned to use.

# LADDERS

## Wooden Ladders

Never paint wooden ladders. Paint hides signs of deterioration and may accelerate rotting by trapping moisture in the wood.

Coat them with a clear, non-toxic wood preservative or varnish. Inspect them frequently for splits, shakes, and cracks in the side rails and rungs, warping or loosening of rungs, losing of metal hardware, and deformation of metal parts.

## Aluminum Ladders

Treat aluminum ladders with care. They are more susceptible to damage than wooden ladders. Because they conduct electricity well, never use aluminum ladders where electrical contact is possible.

- Check side rails and rungs regularly for dents, bends, and loose rungs. If repair by a qualified person is not possible, the ladder must be destroyed.

## Job-Built Ladders

Wood used for job-built ladders should be straight-grained and free of loose knots, sharp edges, splinters, and shakes. The ladder should not be longer than 24 feet in working length. Used by many workers, job-built ladders deteriorate rapidly. They should be inspected every day and, if defective, repaired immediately or taken out of service and destroyed.

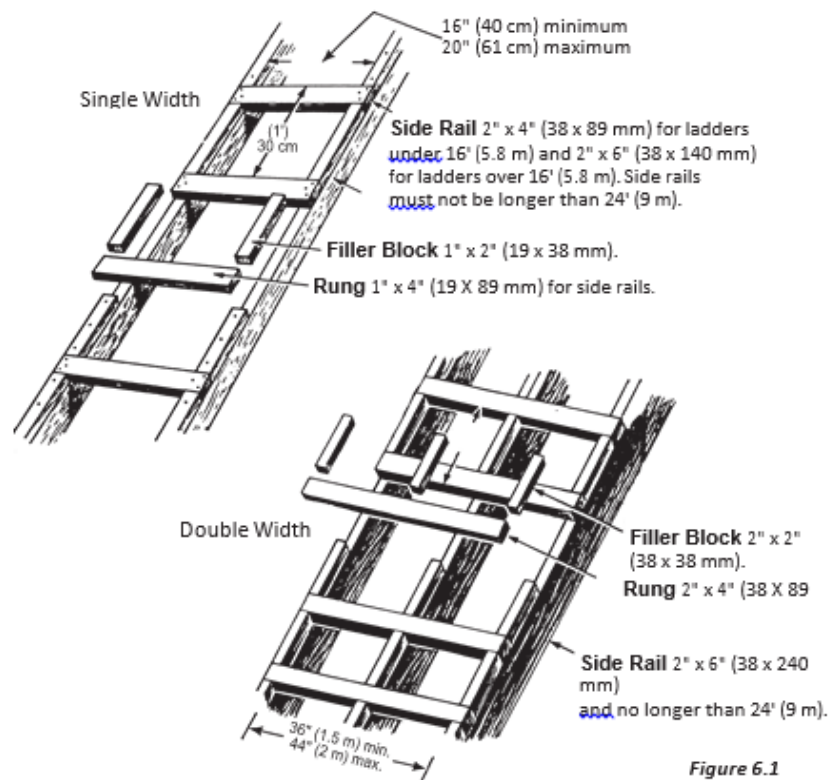

Figure 6.1

## LADDERS

### Ladder Use

Check ladder for defects before use.

Clear scrap and material away from the base and top of ladder.

Secure the top and base against movement.

Set the ladder on a firm, level surface. On soft, uncompacted or rough soil, use a mud sill.

Make sure that rails on ladders extend at least 3 feet above the landing. This allows for secure grip while stepping on or off.

A ladder used as a regular means of access must;

Extend 3 feet above the landing or floor

Have a clear toe space of at least 10 inches behind every rung

Have sufficient clearance from obstructions on the climbing side

Be located so that an adequate landing area is clear of obstructions at the top and bottom

Be secured at the top and bottom to prevent movement.

Set straight or extension ladders one foot out for every 4 feet up, depending on length of ladder (Figure 6.3).

Before setting up ladders, always check for overhead power lines.

Do not position ladders against flexible or moveable surfaces.

Always face the ladder when climbing up or down and while working from it.

Maintain 3- point contact when climbing up or down. That means two hands and one foot or two feet and one hand on the ladder at all time.

Keep your center of gravity between the side rails. Your belt buckle should never be outside the side rails.

When climbing up or down, do not carry tools or materials in your hands. Use a hoist rope instead.

Keep boots clean of mud, grease, or any slippery materials which could cause loss of footing (Figure 6.5).

Never erect ladders on boxes, carts, tables, or other unstable surfaces.

Never use ladders horizontally as scaffolds planks, runaways, or for any other purpose for which they have not been designed.

Stand no higher than the third or fourth rung from the top. Maintain knee contact for balance.

Do not splice short ladders together to make a long ladder. The side rails will not be strong enough for the extra loads.

Do not use ladders for bracing. They are not designed for this type of loading.

Do not set up ladders in doorways, passageways, driveways, or any other location where they can be struck or knocked over.

Never rest a ladder on its rungs. Ladders must rest on their side rails.

To erect long, awkward or heavy ladders, get help to avoid injury from overexertion.

# LADDERS

## Inspection and Maintenance

Ladders shall be inspected by a competent person for visible defects on a periodic basis and after any occurrence that could affect their safe use.

Ladders should only be repaired by qualified persons.

Defective ladders must be taken out of service and both locked and tagged for repair or scrapped.

Inspect ladders for structural rigidity.

Inspect non-skid feet for wear, imbedded material, and proper pivot action on swivel feet.

Replace frayed or worn ropes on extension ladders with types and sizes equal to manufacturer's original rope.

Check aluminum ladders for dents and bends in side rails, steps, and rungs.

Do not use metal pipe to replace rungs.

Check wooden ladders for cracks, slits, and rot.

Check all ladders for grease, oil, caulking, imbedded stone and metal, or other materials that could make them unsafe.



## **Ladder Safety Checklist**

To prevent falls from ladders, make sure you have the following controls in place:

Use only ladders that are in good condition and designed to handle the climbing job that needs to be done.

Train employees on proper ladder use.

Make proper ladder use a performance requirement for the job.

Require employees to complete a ladder inspection before each use.

---

## **Criteria for Ladder Purchase and Care**

- Check OSHA standards for the type of ladder you are using.
- Use only Underwriter's Laboratory approved ladders (will have the UL seal).
- Protect wood ladders with a clear sealer, such as varnish, shellac, linseed oil or wood preservative because paint can hide defects.

## **Temporary Stairs**

The following requirements apply to stairways used temporarily during construction. Except during construction of the stairway,

- Do not use stairways with metal pan landings and treads if the treads and/or landings have not been filled in with concrete or other materials unless the pans of the stairs and/or landings are temporarily filled in with wood or other materials. All treads and landings must be replaced when worn below the top edge of the pan.
- Do not use skeleton metal frame structures and steps (where treads and/or landings will be installed later) unless the stairs are fitted with secured temporary treads and landings.

Note: Temporary treads must be made of wood or other solid material and installed the full width and depth of the stair.

## **Stair Rails**

- The following general requirements apply to all stair rails:
- Stairways with four or more risers or rising more than 30 inches (76 cm) in height—whichever is less—must be installed along each unprotected side or edge. When the top edge of a stair rail system also serves as a handrail, the height of the top edge must be no more than 37 inches (94 cm) nor less than 36 inches (91.5 cm) from the upper surface of the stair rail to the surface of the tread.
- Stair rails installed after March 15, 1991, must be not less than 36 inches (91.5 cm) in height.
- Top edges of stair rail systems used as handrails must not be more than 37 inches (94 cm) high nor less than 36 inches (91.5 cm) from the upper surface of the stair rail system to the surface of the tread. (If installed before March 15, 1991, not less than 30 inches [76 cm]).
- Stair rail systems and handrails must be surfaced to prevent injuries such as punctures or lacerations and to keep clothing from snagging.
- Ends of stair rail systems and handrails must be built to prevent dangerous projections, such as rails protruding beyond the end posts of the system.

### **In addition,**

- Unprotected sides and edges of stairway landings must have standard 42-inch (1.1 m) guardrail systems.
- Intermediate vertical members, such as balusters used as guardrails, must not be more than 19 inches (48 cm) apart.
- Other intermediate structural members, when used, must be installed so that no openings are more than 19 inches (48 cm) wide.
- Screens or mesh, when used, must extend from the top rail to the stairway step and along the opening between top rail supports.

### **Handrails**

Requirements for handrails are as follows:

- Handrails and top rails of the stair rail systems must be able to withstand, without failure, at least 200 pounds (890 n) of weight applied within 2 inches (5 cm) of the top edge in any downward or outward direction, at any point along the top edge.
- Handrails must not be more than 37 inches (94 cm) high nor less than 30 inches (76 cm) from the upper surface of the handrail to the surface of the tread.
- Handrails must provide an adequate handhold for employees to grasp to prevent falls.
- Temporary handrails must have a minimum clearance of 3 inches (8 cm) between the handrail and walls, stair rail systems and other objects.
- Stairways with four or more risers, or that rise more than 30 inches (76 cm) in height—whichever is less—must have at least one handrail.
- Winding or spiral stairways must have a handrail to prevent use of areas where the tread width is less than 6 inches (15 cm).

### **Midrails**

Midrails, screens, mesh, intermediate vertical members or equivalent intermediate structural members must be provided between the top rail and stairway steps to the stair rail system. When midrails are used, they must be located midway between the top of the stair rail system and the stairway steps.



## **Aerial Lifts – OSHA Fact Sheet**

An aerial lift is any vehicle-mounted device used to elevate personnel, including:

- Extendable boom platforms,
- Aerial ladders,
- Articulating (jointed) boom platforms,
- Vertical towers, and
- Any combination of the above.

Aerial lifts have replaced ladders and scaffolding on many job sites due to their mobility and flexibility. They may be made of metal, fiberglass-reinforced plastic, or other materials. They may be powered or manually operated, and are considered to be aerial lifts whether or not they can rotate around a primarily vertical axis.

Many workers are injured or killed on aerial lifts each year.

OSHA provides the following information to help employers and workers recognize and avoid safety hazards they may encounter when they use aerial lifts.

### **Hazards Associated with Aerial Lifts**

The following hazards, among others, can lead to personal injury or death:

- Fall from elevated level,
- Objects falling from lifts,
- Tip-overs,
- Ejections from the lift platform,
- Structural failures (collapses),
- Electric shock (electrocutions),
- Entanglement hazards,
- Contact with objects, and
- Contact with ceilings and other overhead objects.

### ***Training***

Only trained and authorized persons are allowed to operate an aerial lift. Training should include:

- Explanations of electrical, fall, and falling object hazards;
- Procedures for dealing with hazards;
- Recognizing and avoiding unsafe conditions in the work setting;
- Instructions for correct operation of the lift (including maximum intended load and load capacity);
- Demonstrations of the skills and knowledge needed to operate an aerial lift before operating it on the job;
- When and how to perform inspections; and
- Manufacturers' requirements.

### **Retraining**

Workers should be retrained if any of the following conditions occur:

- An accident occurs during aerial lift use,
- Workplace hazards involving an aerial lift are discovered, or
- A different type of aerial lift is used.

Employers are also required to retrain workers who they observe operating an aerial lift improperly.

## What to Do Before Operating an Aerial Lift

### Pre-start Inspection

Prior to each work shift, conduct a pre-start inspection to verify that the equipment and all its components are in safe operating condition. Follow the manufacturer's recommendations and include a check of:

#### *Vehicle components*

- Proper fluid levels (oil, hydraulic, fuel and coolant);
- Leaks of fluids;
- Wheels and tires;
- Battery and charger;
- Lower-level controls;
- Horn, gauges, lights and backup alarms;
- Steering and brakes.

#### *Lift components*

- Operating and emergency controls;
- Personal protective devices;
- Hydraulic, air, pneumatic, fuel and electrical systems;
- Fiberglass and other insulating components;
- Missing or unreadable placards, warnings, or operational, instructional and control markings;
- Mechanical fasteners and locking pins;
- Cable and wiring harnesses;
- Outriggers, stabilizers and other structures;
- Loose or missing parts;
- Guardrail systems.

Do not operate any aerial lift if any of these components are defective until it is repaired by a qualified person. Remove defective aerial lifts from service (tag out) until repairs are made.

### Work Zone Inspections

Employers must assure that work zones are inspected for hazards and take corrective actions to eliminate such hazards before and during operation of an aerial lift. Items to look for include:

- Drop-offs, holes, or unstable surfaces such as loose dirt;
- Inadequate ceiling heights;
- Slopes, ditches, or bumps;
- Debris and floor obstructions;
- Overhead electric power lines and communication cables;
- Other overhead obstructions;
- Other hazardous locations and atmospheres;
- High wind and other severe weather conditions, such as ice; and
- The presence of others in close proximity to the work.

# AERIAL LIFTS

## ***What to Do While Operating an Aerial Lift***

### **Fall Protection:**

- Ensure that access gates or openings are closed.
- Stand firmly on the floor of the bucket or lift platform.
- Do not climb on or lean over guardrails or handrails.
- Do not use planks, ladders, or other devices as a working position.
- When using an extensible or articulating boom platform, use a body harness or a restraining belt with a lanyard attached to the boom or bucket. *Note: This regulation does not apply to scissors lifts.*
- Do not belt-off to adjacent structures or poles while in the bucket.

### **Operation/Traveling/Loading:**

- Do not exceed the load-capacity limits. Take the combined weight of the worker(s), tools and materials into account when calculating the load.
- Do not use the aerial lift as a crane.
- Do not carry objects larger than the platform.
- Do not drive with the lift platform raised (unless the manufacturer's instructions allow this).
- Do not operate lower level controls unless permission is obtained from the worker(s) in the lift (except in emergencies).
- Do not exceed vertical or horizontal reach limits.
- Do not operate an aerial lift in high winds above those recommended by the manufacturer.
- Do not override hydraulic, mechanical, or electrical safety devices.

### **Overhead Protection:**

- Be aware of overhead clearance and overhead objects, including ceilings.
- Do not position aerial lifts between overhead hazards if possible.
- Treat all overhead power lines and communication cables as energized, and stay at least 10 feet (3 meters) away.
- Ensure that the power utility or power line workers de-energize power lines in the vicinity of the work.

### **Stability in the Work Zone:**

- Set outriggers on pads or on a level, solid surface.
- Set brakes when outriggers are used.
- Use wheel chocks on sloped surfaces when it is safe to do so.
- Set up work zone warnings, such as cones and signs, when necessary to warn others.

Insulated aerial lifts offer protection from electric shock and electrocution by isolating you from electrical ground. However, an insulated aerial lift does not protect you if there is another path to ground (for instance, if you touch another wire). To maintain the effectiveness of the insulating device, do not drill holes in the bucket.

## ***Standards that Apply***

### **OSHA Standards:**

29 CFR 1910.67, 29 CFR 1910.269(p), 29 CFR 1926.21, 29 CFR 1926.453, 29 CFR 1926.502.

### **American National Standards Institutes standards:**

ANSI/SIA A92.2-1969, ANSI/SIA A92.3, ANSI/SIA A92.5, ANSI/SIA A92.6.

**Scaffolding**

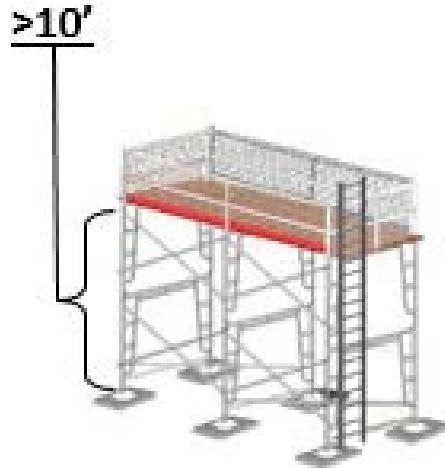

1926.451(g)(1) Each employee on a scaffold more than 10 feet (3.1 m) above a lower level shall be protected from falling to that lower level. Paragraphs (g)(1)(i) through (vii) of this section establish the types of fall protection to be provided to the employees on each type of scaffold. Paragraph (g)(2) of this section addresses fall protection for scaffold erectors and dismantlers.

Note to paragraph (g)(1): The fall protection requirements for employees installing suspension scaffold support systems on floors, roofs, and other elevated surfaces are set forth in subpart M of this part.

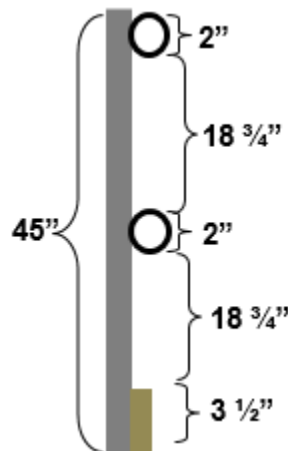

1926.451(g)(4)(ii) The top edge height of top rails or equivalent member on supported scaffolds manufactured or placed in service after January 1, 2000 shall be installed between 38 inches (0.97 m) and 45 inches (1.2 m) above the platform surface. The top edge height on supported scaffolds manufactured and placed in service before January 1, 2000, and on all suspended scaffolds where both a guardrail and a personal fall arrest system are required shall be between 36 inches (0.9 m) and 45 inches (1.2 m). When conditions warrant, the height of the top edge may exceed the 45-inch height, provided the guardrail system meets all other criteria of paragraph (g)(4).

## SCAFFOLDING

1926.451(g)(4)(vi) When intermediate members (such as balusters or additional rails) are used, they shall not be more than 19 inches (48 cm) apart.

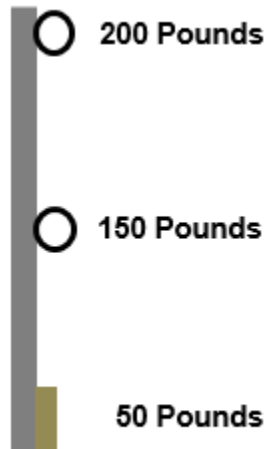

1926.451(g)(4)(vii) Each toprail or equivalent member of a guardrail system shall be capable of withstanding, without failure, a force applied in any downward or horizontal direction at any point along its top edge of at least 100 pounds (445 n) for guardrail systems installed on single-point adjustable suspension scaffolds or two-point adjustable suspension scaffolds, and at least 200 pounds (890 n) for guardrail systems installed on all other scaffolds.

1926.451(g)(4)(ix) Midrails, screens, mesh, intermediate vertical members, solid panels, and equivalent structural members of a guardrail system shall be capable of withstanding, without failure, a force applied in any downward or horizontal direction at any point along the midrail or other member of at least 75 pounds (333 n) for guardrail systems with a minimum 100 pound toprail capacity, and at least 150 pounds (666 n) for guardrail systems with a minimum 200 pound toprail capacity.

1926.451(h)(4)(i)(ii) Capable of withstanding, without failure, a force of at least 50 pounds (222 n) applied in any downward or horizontal direction at any point along the toeboard; and have not more than 1/4 inch (0.7 cm) clearance above the walking/working surface

*Crossbracing*

Crossbracing  
20" - 30" = Midrail

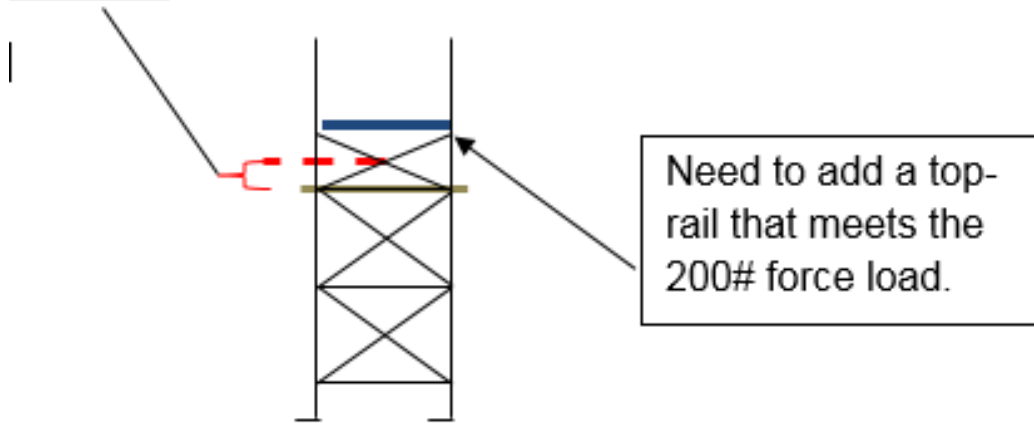

1926.451(g)(4)(xv) Crossbracing is acceptable in place of a midrail when the crossing point of two braces is between 20 inches (0.5 m) and 30 inches (0.8 m) above the work platform or as a top rail when the crossing point of two braces is between 38 inches (0.97 m) and 48 inches (1.3 m) above the work platform. The end points at each upright shall be no more than 48 inches (1.3 m) apart.

Crossbracing  
38" - 48" = Toprail

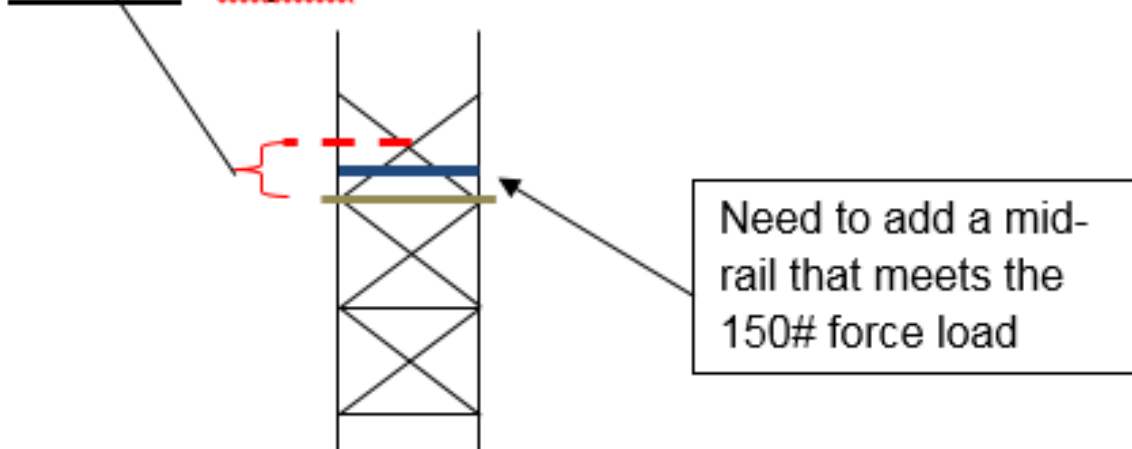

1926.451(g)(4)(xv) Crossbracing is acceptable in place of a midrail when the crossing point of two braces is between 20 inches (0.5 m) and 30 inches (0.8 m) above the work platform or as a top rail when the crossing point of two braces is between 38 inches (0.97 m) and 48 inches (1.3 m) above the work platform. The end points at each upright shall be no more than 48 inches (1.3 m) apart.

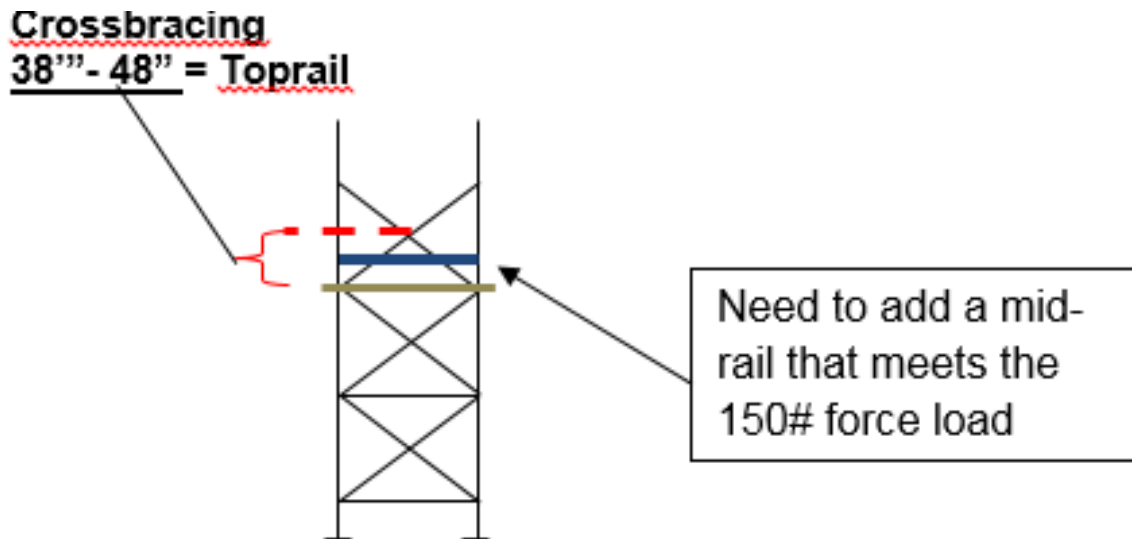

1926.451(g)(4)(xv) Crossbracing is acceptable in place of a midrail when the crossing point of two braces is between 20 inches (0.5 m) and 30 inches (0.8 m) above the work platform or as a toprail when the crossing point of two braces is between 38 inches (0.97 m) and 48 inches (1.3 m) above the work platform. The end points at each upright shall be no more than 48 inches (1.3 m) apart.

***\*Crossbracing can be used as a top-rail, mid-rail, or neither, but never both\****

**DEPARTMENT OF LABOR**

**OCCUPATIONAL SAFETY AND HEALTH ADMINISTRATION**

**29 CFR PARTS 1926 – SUBPART M**

**FALL PROTECTION IN CONSTRUCTION**

**§1926.500(a) Scope and application.**

(1) This subpart sets forth requirements and criteria for fall protection in construction workplaces covered under 29 CFR part 1926. Exception: The provisions of this subpart do not apply when employees are making an inspection, investigation, or assessment of workplace conditions prior to the actual start of construction work or after all construction work has been completed.

(2) Section 1926.501 sets forth those workplaces, conditions, operations, and circumstances for which fall protection shall be provided except as follows:

(i) Requirements relating to fall protection for employees working on scaffolds are provided in subpart L of this part.

(ii) Requirements relating to fall protection for employees working on cranes and derricks are provided in subpart CC of this part.

(iii) Fall protection requirements for employees performing steel erection work (except for towers and tanks) are provided in subpart R of this part.

(iv) Requirements relating to fall protection for employees working on certain types of equipment used in tunneling operations are provided in subpart S of this part.

(v) Requirements relating to fall protection for employees engaged in the erection of tanks and communication and broadcast towers are provided in § 1926.105.

(vi) Subpart V of this part provides requirements relating to fall protection for employees working from aerial lifts or on poles, towers, or similar structures while engaged in the construction of electric transmission or distribution lines or equipment.

(vii) Requirements relating to fall protection for employees working on stairways and ladders are provided in subpart X of this part.

(3) Section 1926.502 sets forth the requirements for the installation, construction, and proper use of fall protection required by part 1926, except as follows:

(i) Performance requirements for guardrail systems used on scaffolds and performance requirements for falling object protection used on scaffolds are provided in subpart L of this part.

(ii) Performance requirements for stairways, stairrail systems, and handrails are provided in subpart X of this part.

(iii) Additional performance requirements for fall arrest and workpositioning equipment are provided in Subpart V of this part.



(iv) Section 1926.502 does not apply to the erection of tanks and communication and broadcast towers. (Note: Section 1926.104 sets the criteria for body belts, lanyards and lifelines used for fall protection during tank and communication and broadcast tower erection. Paragraphs (b), (c) and (f) of §1926.107 provide definitions for the pertinent terms.)

(v) Criteria for steps, handholds, ladders, and grabrails/guardrails/railings required by subpart CC are provided in subpart CC. Sections 1926.502(a), (c) through (e), and (i) apply to activities covered under subpart CC unless otherwise stated in subpart CC. No other paragraphs of §1926.502 apply to subpart CC.

(4) Section 1926.503 sets forth requirements for training in the installation and use of fall protection systems, except in relation to steel erection activities and the use of equipment covered by subpart CC (Cranes and Derricks in Construction).

### **§1926.500(b) Definitions applicable to this subpart.**

**ANCHORAGE** means a secure point of attachment for lifelines, lanyards or deceleration devices.

**BODY BELT (SAFETY BELT)** means a strap with means both for securing it about the waist and for attaching it to a lanyard, lifeline, or deceleration device.

**BODY HARNESS** means straps which may be secured about the employee in a manner that will distribute the fall arrest forces over at least the thighs, pelvis, waist, chest and shoulders with means for attaching it to other components of a personal fall arrest system.

**BUCKLE** means any device for holding the body belt or body harness closed around the employee's body.

**CONNECTOR** means a device which is used to couple (connect) parts of the personal fall arrest system and positioning device systems together. It may be an independent component of the system, such as a carabineer, or it may be an integral component of part of the system (such as a buckle or dee-ring sewn into a body belt or body harness, or a snap-hook spliced or sewn to a lanyard or self-retracting lanyard).

**CONTROLLED ACCESS ZONE (CAZ)** means an area in which certain work (e.g., overhand bricklaying) may take place without the use of guardrail systems, personal fall arrest systems, or safety net systems and access to the zone is controlled.

**DANGEROUS EQUIPMENT** means equipment (such as pickling or galvanizing tanks, degreasing units, machinery, electrical equipment, and other units) which, as a result of form or function, may be hazardous to employees who fall onto or into such equipment.

**DECELERATION DEVICE** means any mechanism, such as a rope grab, rip-stitch lanyard, specially-woven lanyard, tearing or deforming lanyards, automatic self-retracting lifelines/lanyards, etc., which serves to dissipate a substantial amount of energy during a fall arrest, or otherwise limit the energy imposed on an employee during fall arrest.

**DECELERATION DISTANCE** means the additional vertical distance a falling employee travels, excluding lifeline elongation and free fall distance, before stopping, from the point at which the deceleration device begins to operate. It is measured as the distance between the location of an employee's body belt or body harness attachment point at the moment of activation (at the onset of fall arrest forces) of the deceleration device during a fall, and the location of that attachment point after the employee comes to a full stop.

**EQUIVALENT** means alternative designs, materials, or methods to protect against a hazard which the employer can demonstrate will provide an equal or greater degree of safety for employees than the methods, materials or designs specified in the standard.

**FAILURE** means load refusal, breakage, or separation of component parts. Load refusal is the point where the ultimate strength is exceeded.

**FREE FALL** means the act of falling before a personal fall arrest system begins to apply force to arrest the fall.

**FREE FALL DISTANCE** means the vertical displacement of the fall arrest attachment point on the employee's body belt or body harness between onset of the fall and just before the system begins to apply force to arrest the fall. This distance excludes deceleration distance, and lifeline/lanyard elongation, but includes any deceleration device slide distance or self-retracting lifeline/lanyard extension before they operate and fall arrest forces occur.

**GUARDRAIL SYSTEM** means a barrier erected to prevent employees from falling to lower levels.

**HOLE** means a gap or void 2 inches (5.1 cm) or more in its least dimension, in a floor, roof, or other walking/working surface.

**INFEASIBLE** means that it is impossible to perform the construction work using a conventional fall protection system (i.e., guardrail system, safety net system, or personal fall arrest system) or that it is technologically impossible to use any one of these systems to provide fall protection.

**LANYARD** means a flexible line of rope, wire rope, or strap which generally has a connector at each end for connecting the body belt or body harness to a deceleration device, lifeline, or anchorage.

**LEADING EDGE** means the edge of a floor, roof, or formwork for a floor or other walking/working surface (such as the deck) which changes location as additional floor, roof, decking, or formwork sections are placed, formed, or constructed. A leading edge is considered to be an "unprotected side and edge" during periods when it is not actively and continuously under construction.

**LIFELINE** means a component consisting of a flexible line for connection to an anchorage at one end to hang vertically (vertical lifeline), or for connection to anchorages at both ends to stretch horizontally (horizontal lifeline), and which serves as a means for connecting other components of a personal fall arrest system to the anchorage.

**LOW-SLOPE ROOF** means a roof having a slope less than or equal to 4 in 12 (vertical to horizontal).

**LOWER LEVELS** means those areas or surfaces to which an employee can fall. Such areas or surfaces include, but are not limited to, ground levels, floors, platforms, ramps, runways, excavations, pits, tanks, material, water, equipment, structures, or portions thereof.

**MECHANICAL EQUIPMENT** means all motor or human propelled wheeled equipment used for roofing work, except wheelbarrows and mop carts.

**OPENING** means a gap or void 30 inches (76 cm) or more high and 18 inches (48 cm) or more wide, in a wall or partition, through which employees can fall to a lower level.

**OVERHAND BRICKLAYING AND RELATED WORK** means the process of laying bricks and masonry units such that the surface of the wall to be jointed is on the opposite side of the wall from the mason, requiring the mason to lean over the wall to complete the work. Related work includes mason tending and electrical installation incorporated into the brick wall during the overhand bricklaying process.

**PERSONAL FALL ARREST SYSTEM** means a system used to arrest an employee in a fall from a working level. It consists of an anchorage, connectors, a body belt or body harness and may include a lanyard, deceleration device, lifeline, or suitable combinations of these. As of January 1, 1998, the use of a body belt for fall arrest is prohibited.

**POSITIONING DEVICE SYSTEM** means a body belt or body harness system rigged to allow an employee to be supported on an elevated vertical surface, such as a wall, and work with both hands free while leaning.

**ROPE GRAB** means a deceleration device which travels on a lifeline and automatically, by friction, engages the lifeline and locks so as to arrest the fall of an employee. A rope grab usually employs the principle of inertial locking, cam/level locking, or both.

**ROOF** means the exterior surface on the top of a building. This does not include floors or formwork which, because a building has not been completed, temporarily become the top surface of a building.

**ROOFING WORK** means the hoisting, storage, application, and removal of roofing materials and equipment, including related insulation, sheet metal, and vapor barrier work, but not including the construction of the roof deck.

**SAFETY-MONITORING SYSTEM** means a safety system in which a competent person is responsible for recognizing and warning employees of fall hazards.

**SELF-RETRACTING LIFELINE/LANYARD** means a deceleration device containing a drum-wound line which can be slowly extracted from, or retracted onto, the drum under slight tension during normal employee movement, and which, after onset of a fall, automatically locks the drum and arrests the fall.

**SNAPHOOK** means a connector comprised of a hook-shaped member with a normally closed keeper, or similar arrangement, which may be opened to permit the hook to receive an object and, when released, automatically closes to retain the object. Snaphooks are generally one of two types:

- (1) The locking type with a self-closing, self-locking keeper which remains closed and locked until unlocked and pressed open for connection or disconnection; or
- (2) The non-locking type with a self-closing keeper which remains closed until pressed open for connection or disconnection. As of January 1, 1998, the use of a non-locking snaphook as part of personal fall arrest systems and positioning device systems is prohibited.

**STEEP ROOF** means a roof having a slope greater than 4 in 12 (vertical to horizontal).

**TOEBOARD** means a low protective barrier that will prevent the fall of materials and equipment to lower levels and provide protection from falls for personnel.

**UNPROTECTED SIDES AND EDGES** means any side or edge (except at entrances to points of access) of a walking/working surface, e.g., floor, roof, ramp, or runway where there is no wall or guardrail system at least 39 inches (1.0 m) high.

**WALKING/WORKING SURFACE** means any surface, whether horizontal or vertical on which an employee walks or works, including, but not limited to, floors, roofs, ramps, bridges, runways, formwork and concrete reinforcing steel but not including ladders, vehicles, or trailers, on which employees must be located in order to perform their job duties.

**WARNING LINE SYSTEM** means a barrier erected on a roof to warn employees that they are approaching an unprotected roof side or edge, and which designates an area in which roofing work may take place without the use of guardrail, body belt, or safety net systems to protect employees in the area.

**WORK AREA** means that portion of a walking/working surface where job duties are being performed.

### §1926.501(a) General

- (1) This section sets forth requirements for employers to provide fall protection systems. All fall protection required by this section shall conform to the criteria set forth in 1926.502 of this subpart.
- (2) The employer shall determine if the walking/working surfaces on which its employees are to work have the strength and structural integrity to support employees safely. Employees shall be allowed to work on those surfaces only when the surfaces have the requisite strength and structural integrity.

### §1926.501(b)

(1) **"Unprotected sides and edges."** Each employee on a walking/working surface (horizontal and vertical surface) with an unprotected side or edge which is 6 feet (1.8 m) or more above a lower level shall be protected from falling by the use of guardrail systems, safety net systems, or personal fall arrest systems.

(2) **"Leading edges."**

(i) Each employee who is constructing a leading edge 6 feet (1.8 m) or more above lower levels shall be protected from falling by guardrail systems, safety net systems, or personal fall arrest systems. Exception: When the employer can demonstrate that it is infeasible or creates a greater hazard to use these systems, the employer shall develop and implement a fall protection plan which meets the requirements of paragraph (k) of 1926.502.

NOTE: There is a presumption that it is feasible and will not create a greater hazard to implement at least one of the above-listed fall protection systems. Accordingly, the employer has the burden of establishing that it is appropriate to implement a fall protection plan which complies with 1926.502(k) for a particular workplace situation, in lieu of implementing any of those systems.

(ii) Each employee on a walking/working surface 6 feet (1.8 m) or more above a lower level where leading edges are under construction, but who is not engaged in the leading edge work, shall be protected from falling by a guardrail system, safety net system, or personal fall arrest system. If a guardrail system is chosen to provide the fall protection, and a controlled access zone has already been established for leading edge work, the control line may be used in lieu of a guardrail along the edge that parallels the leading edge.

(3) **"Hoist areas."** Each employee in a hoist area shall be protected from falling 6 feet (1.8 m) or more to lower levels by guardrail systems or personal fall arrest systems. If guardrail systems, [or chain, gate, or guardrail] or portions thereof, are removed to facilitate the hoisting operation (e.g., during landing of materials), and an employee must lean through the access opening or out over the edge of the access opening (to receive or guide equipment and materials, for example), that employee shall be protected from fall hazards by a personal fall arrest system.

(4) **"Holes."**

(i) Each employee on walking/working surfaces shall be protected from falling through holes (including skylights) more than 6 feet (1.8 m) above lower levels, by personal fall arrest systems, covers, or guardrail systems erected around such holes.

- (ii) Each employee on a walking/working surface shall be protected from tripping in or stepping into or through holes (including skylights) by covers.
- (iii) Each employee on a walking/working surface shall be protected from objects falling through holes (including skylights) by covers.
- (5) **"Formwork and reinforcing steel."** Each employee on the face of formwork or reinforcing steel shall be protected from falling 6 feet (1.8 m) or more to lower levels by personal fall arrest systems, safety net systems, or positioning device systems.
- (6) **"Ramps, runways, and other walkways."** Each employee on ramps, runways, and other walkways shall be protected from falling 6 feet (1.8 m) or more to lower levels by guardrail systems.
- (7) **"Excavations."**
  - (i) Each employee at the edge of an excavation 6 feet (1.8 m) or more in depth shall be protected from falling by guardrail systems, fences, or barricades when the excavations are not readily seen because of plant growth or other visual barrier;
  - (ii) Each employee at the edge of a well, pit, shaft, and similar excavation 6 feet (1.8 m) or more in depth shall be protected from falling by guardrail systems, fences, barricades, or covers.
- (8) **"Dangerous equipment."**
  - (i) Each employee less than 6 feet (1.8 m) above dangerous equipment shall be protected from falling into or onto the dangerous equipment by guardrail systems or by equipment guards.
  - (ii) Each employee 6 feet (1.8 m) or more above dangerous equipment shall be protected from fall hazards by guardrail systems, personal fall arrest systems, or safety net systems.

#### §1926.501(b)

- (9) **"Overhand bricklaying and related work."**
  - (i) Except as otherwise provided in paragraph (b) of this section, each employee performing overhand bricklaying and related work 6 feet (1.8 m) or more above lower levels, shall be protected from falling by guardrail systems, safety net systems, personal fall arrest systems, or shall work in a controlled access zone.
  - (ii) Each employee reaching more than 10 inches (25 cm) below the level of the walking/working surface on which they are working, shall be protected from falling by a guardrail system, safety net system, or personal fall arrest system.

NOTE: Bricklaying operations performed on scaffolds are regulated by subpart L - Scaffolds of this part.

- (10) **"Roofing work on Low-slope roofs."** Except as otherwise provided in paragraph (b) of this section, each employee engaged in roofing activities on low-slope roofs, with unprotected sides and edges 6 feet (1.8 m) or more above lower levels shall be protected from falling by guardrail systems, safety net systems, personal fall arrest systems, or a combination of warning line system and guardrail system, warning line system and safety net system, or warning line system and personal fall arrest system, or warning line system and safety monitoring system. Or, on roofs 50-feet (15.25 m) or less in width (see Appendix A to subpart M of this part), the use of a safety monitoring system alone [i.e. without the warning line system] is permitted.

(11) **"Steep roofs."** Each employee on a steep roof with unprotected sides and edges 6 feet (1.8 m) or more above lower levels shall be protected from falling by guardrail systems with toeboards, safety net systems, or personal fall arrest systems.

(12) **"Precast concrete erection."** Each employee engaged in the erection of precast concrete members (including, but not limited to the erection of wall panels, columns, beams, and floor and roof "tees") and related operations such as grouting of precast concrete members, who is 6 feet (1.8 m) or more above lower levels shall be protected from falling by guardrail systems, safety net systems, or personal fall arrest systems, unless another provision in paragraph (b) of this section provides for an alternative fall protection measure. Exception: When the employer can demonstrate that it is infeasible or creates a greater hazard to use these systems, the employer shall develop and implement a fall protection plan which meets the requirements of paragraph (k) of 1926.502.

(13) **"Residential construction."** Each employee engaged in residential construction activities 6 feet (1.8 m) or more above lower levels shall be protected by guardrail systems, safety net system, or personal fall arrest system unless another provision in paragraph (b) of this section provides for an alternative fall protection measure. Exception: When the employer can demonstrate that it is infeasible or creates a greater hazard to use these systems, the employer shall develop and implement a fall protection plan which meets the requirements of paragraph (k) of 1926.502.

NOTE: There is a presumption that it is feasible and will not create a greater hazard to implement at least one of the above-listed fall protection systems. Accordingly, the employer has the burden of establishing that it is appropriate to implement a fall protection plan which complies with 1926.502(k) for a particular workplace situation, in lieu of implementing any of those systems.

(14) **"Wall openings."** Each employee working on, at, above, or near wall openings (including those with chutes attached) where the outside bottom edge of the wall opening is 6 feet (1.8 m) or more above lower levels and the inside bottom edge of the wall opening is less than 39 inches (1.0 m) above the walking/working surface, shall be protected from falling by the use of a guardrail system, a safety net system, or a personal fall arrest system.

(15) **"Walking/working surfaces not otherwise addressed."** Except as provided in 1926.500(a)(2) or in 1926.501 (b)(1) through (b)(14), each employee on a walking/working surface 6 feet (1.8 m) or more above lower levels shall be protected from falling by a guardrail system, safety net system, or personal fall arrest system.

### §1926.501(c) Protection from Falling Objects

**"Protection from falling objects."** When an employee is exposed to falling objects, the employer shall have each employee wear a hard hat and shall implement one of the following measures:

- (1) Erect toeboards, screens, or guardrail systems to prevent objects from falling from higher levels; or,
- (2) Erect a canopy structure and keep potential fall objects far enough from the edge of the higher level so that those objects would not go over the edge if they were accidentally displaced; or,
- (3) Barricade the area to which objects could fall, prohibit employees from entering the barricaded area, and keep objects that may fall far enough away from the edge of a higher level so that those objects would not go over the edge if they were accidentally displaced.

### §1926.502(a) General

- (1) Fall protection systems required by this part shall comply with the applicable provisions of this section.
- (2) Employers shall provide and install all fall protection systems required by this subpart for an employee, and shall comply with all other pertinent requirements of this subpart before that employee begins the work that necessitates the fall protection.

NOTE: in situations where the status of appropriate anchorages are unknown or suspected to be inadequate, employers should discuss safe ways to access areas where work is to be conducted. Such planning should anticipate where proper anchorages are to be located prior to work being started instead of using alternative anchorage points which may not comply with this subpart. (Standard Interpretation Letter)

### §1926.502(b) Guardrail Systems

Guardrail systems and their use shall comply with the following provisions:

- (1) Top edge height of top rails, or equivalent guardrail system members, shall be 42 inches (1.1 m) plus or minus 3 inches (8 cm) above the walking/working level. When conditions warrant, the height of the top edge may exceed the 45-inch height, provided the guardrail system meets all other criteria of this paragraph.

NOTE: When employees are using stilts, the top edge height of the top rail, or equivalent member, shall be increased an amount equal to the height of the stilts.

- (2) Midrails, screens, mesh, intermediate vertical members, or equivalent intermediate structural members shall be installed between the top edge of the guardrail system and the walking/working surface when there is no wall or parapet wall at least 21 inches (53 cm) high.
  - (i) Midrails, when used, shall be installed at a height midway between the top edge of the guardrail system and the walking/working level.
  - (ii) Screens and mesh, when used, shall extend from the top rail to the walking/working level and along the entire opening between top rail supports.
  - (iii) Intermediate members (such as balusters), when used between posts, shall be not more than 19 inches (48 cm) apart.
  - (iv) Other structural members (such as additional midrails and architectural panels) shall be installed such that there are no openings in the guardrail system that are more than 19 inches (.5 m) wide.
- (3) Guardrail systems shall be capable of withstanding, without failure, a force of at least 200 pounds (890 N) applied within 2 inches (5.1 cm) of the top edge, in any outward or downward direction, at any point along the top edge.
- (4) When the 200 pound (890 N) test load specified in paragraph (b)(3) of this section is applied in a downward direction, the top edge of the guardrail shall not deflect to a height less than 39 inches (1.0 m) above the walking/working level. Guardrail system components selected and constructed in accordance with the Appendix B to subpart M of this part will be deemed to meet this requirement.

- (5) Midrails, screens, mesh, intermediate vertical members, solid panels, and equivalent structural members shall be capable of withstanding, without failure, a force of at least 150 pounds (666 N) applied in any downward or outward direction at any point along the midrail or other member.
- (6) Guardrail systems shall be so surfaced as to prevent injury to an employee from punctures or lacerations, and to prevent snagging of clothing.
- (7) The ends of all top rails and midrails shall not overhang the terminal posts, except where such overhang does not constitute a projection hazard.
- (8) Steel banding and plastic banding shall not be used as top rails or midrails.
- (9) Top rails and midrails shall be at least one-quarter inch (0.6 cm) nominal diameter or thickness to prevent cuts and lacerations. If wire rope is used for top rails, it shall be flagged at not more than 6-foot intervals with high-visibility material.
- (10) When guardrail systems are used at hoisting areas, a chain, gate or removable guardrail section shall be placed across the access opening between guardrail sections when hoisting operations are not taking place.
- (11) When guardrail systems are used at holes, they shall be erected on all unprotected sides or edges of the hole.
- (12) When guardrail systems are used around holes used for the passage of materials, the hole shall have not more than two sides provided with removable guardrail sections to allow the passage of materials. When the hole is not in use, it shall be closed over with a cover, or a guardrail system shall be provided along all unprotected sides or edges.
- (13) When guardrail systems are used around holes which are used as points of access (such as ladderways), they shall be provided with a gate, or be so offset that a person cannot walk directly into the hole.
- (14) Guardrail systems used on ramps and runways shall be erected along each unprotected side or edge.
- (15) Manila, plastic or synthetic rope being used for top rails or midrails shall be inspected as frequently as necessary to ensure that it continues to meet the strength requirements of paragraph (b)(3) of this section.

**§1926.502(c) Safety Net Systems**

Safety net systems and their use shall comply with the following provisions:

- (1) Safety nets shall be installed as close as practicable under the walking/working surface on which employees are working, but in no case more than 30 feet (9.1 m) below such level. When nets are used on bridges, the potential fall area from the walking/working surface to the net shall be unobstructed.
- (2) Safety nets shall extend outward from the outermost projection of the work surface as follows:

Vertical distance from working level to horizontal plane of net. Maximum required horizontal distance of outer edge of net from the edge of the working surface.

Up to 5 feet ..... 8 feet.



More than 5 feet up to 10 feet 10 feet.

More than 10 feet ..... 13 feet.

(3) Safety nets shall be installed with sufficient clearance under them to prevent contact with the surface or structures below when subjected to an impact force equal to the drop test specified in paragraph (c)(4) of this section.

(4) Safety nets and their installations shall be capable of absorbing an impact force equal to that produced by the drop test specified in paragraph (c)(4)(i) of this section.

(i) Except as provided in paragraph (c)(4)(ii) of this section, safety nets and safety net installations shall be drop-tested at the jobsite after initial installation and before being used as a fall protection system, whenever relocated, after major repair, and at 6-month intervals if left in one place. The drop-test shall consist of a 400 pound (180 kg) bag of sand 30 + or - 2 inches (76 + or - 5 cm) in diameter dropped into the net from the highest walking/working surface at which employees are exposed to fall hazards, but not from less than 42 inches (1.1 m) above that level.

(ii) When the employer can demonstrate that it is unreasonable to perform the drop-test required by paragraph (c)(4)(i) of this section, the employer (or a designated competent person) shall certify that the net and net installation is in compliance with the provisions of paragraphs (c)(3) and (c)(4)(i) of this section by preparing a certification record prior to the net being used as a fall protection system. The certification record must include an identification of the net and net installation for which the certification record is being prepared; the date that it was determined that the identified net and net installation were in compliance with paragraph (c)(3) of this section and the signature of the person making the determination and certification. The most recent certification record for each net and net installation shall be available at the jobsite for inspection.

(5) Defective nets shall not be used. Safety nets shall be inspected at least once a week for wear, damage, and other deterioration. Defective components shall be removed from service. Safety nets shall also be inspected after any occurrence which could affect the integrity of the safety net system.

(6) Materials, scrap pieces, equipment, and tools which have fallen into the safety net shall be removed as soon as possible from the net and at least before the next work shift.

(7) The maximum size of each safety net mesh opening shall not exceed 36 square inches (230 cm) nor be longer than 6 inches (15 cm) on any side, and the opening, measured center-to-center of mesh ropes or webbing, shall not be longer than 6 inches (15 cm). All mesh crossings shall be secured to prevent enlargement of the mesh opening.

(8) Each safety net (or section of it) shall have a border rope for webbing with a minimum breaking strength of 5,000 pounds (22.2 kN).

(9) Connections between safety net panels shall be as strong as integral net components and shall be spaced not more than 6 inches (15 cm) apart.

**§1926.502(d) Personal Fall Arrest Systems**

Personal fall arrest systems and their use shall comply with the provisions set forth below. Effective January 1, 1998, body belts are not acceptable as part of a personal fall arrest system.

NOTE: The use of a body belt in a positioning device system is acceptable and is regulated under paragraph (e) of this section.

- (1) Connectors shall be drop forged, pressed or formed steel, or made of equivalent materials.
- (2) Connectors shall have a corrosion-resistant finish, and all surfaces and edges shall be smooth to prevent damage to interfacing parts of the system.
- (3) Dee-rings and snaphooks shall have a minimum tensile strength of 5,000 pounds (22.2 kN).
- (4) Dee-rings and snaphooks shall be proof-tested to a minimum tensile load of 3,600 pounds (16 kN) without cracking, breaking, or taking permanent deformation.
- (5) Snaphooks shall be sized to be compatible with the member to which they are connected to prevent unintentional disengagement of the snaphook by depression of the snaphook keeper by the connected member, or shall be a locking type snaphook designed and used to prevent disengagement of the snaphook by the contact of the snaphook keeper by the connected member. Effective January 1, 1998, only locking type snaphooks shall be used.
- (6) Unless the snaphook is a locking type and designed for the following connections, snaphooks shall not be engaged:
  - (i) directly to webbing, rope or wire rope;
  - (ii) to each other;
  - (iii) to a dee-ring to which another snaphook or other connector is attached;
  - (iv) to a horizontal lifeline; or
  - (v) to any object which is incompatibly shaped or dimensioned in relation to the snaphook such that unintentional disengagement could occur by the connected object being able to depress the snaphook keeper and release itself.
- (7) On suspended scaffolds or similar work platforms with horizontal lifelines which may become vertical lifelines, the devices used to connect to a horizontal lifeline shall be capable of locking in both directions on the lifeline.
- (8) Horizontal lifelines shall be designed, installed, and used, under the supervision of a qualified person, as part of a complete personal fall arrest system, which maintains a safety factor of at least two.
- (9) Lanyards and vertical lifelines shall have a minimum breaking strength of 5,000 pounds (22.2 kN).
- (10) Except as provided in paragraph (d)(10)(ii) of this section, when vertical lifelines are used, each employee shall be attached to a separate lifeline.
  - (i) Except as provided in paragraph (d)(10)(ii) of this section, when vertical lifelines are used, each employee shall be attached to a separate lifeline.
  - (ii) During the construction of elevator shafts, two employees may be attached to the same lifeline in the hoistway, provided both employees are working atop a false car that is equipped with guardrails; the strength of the lifeline is 10,000 pounds [5,000 pounds per employee attached] (44.4 kN); and all other criteria specified in this paragraph for lifelines have been met.

- (11) Lifelines shall be protected against being cut or abraded.
- (12) Self-retracting lifelines and lanyards which automatically limit free fall distance to 2 feet (0.61 m) or less shall be capable of sustaining a minimum tensile load of 3,000 pounds (13.3 kN) applied to the device with the lifeline or lanyard in the fully extended position.
- (13) Self-retracting lifelines and lanyards which do not limit free fall distance to 2 feet (0.61 m) or less, ripstitch lanyards, and tearing and deforming lanyards shall be capable of sustaining a minimum tensile load of 5,000 pounds (22.2 kN) applied to the device with the lifeline or lanyard in the fully extended position.
- (14) Ropes and straps (webbing) used in lanyards, lifelines, and strength components of body belts and body harnesses shall be made from synthetic fibers.

### **§1926.502(d) Personal Fall Arrest Systems**

- (15) Anchorages used for attachment of personal fall arrest equipment shall be independent of any anchorage being used to support or suspend platforms and capable of supporting at least 5,000 pounds (22.2 kN) per employee attached, or shall be designed, installed, and used as follows:
  - (i) as part of a complete personal fall arrest system which maintains a safety factor of at least two; and
  - (ii) under the supervision of a qualified person.
- (16) Personal fall arrest systems, when stopping a fall, shall:
  - (i) limit maximum arresting force on an employee to 900 pounds (4 kN) when used with a body belt;
  - (ii) limit maximum arresting force on an employee to 1,800 pounds (8 kN) when used with a body harness;
  - (iii) be rigged such that an employee can neither free fall more than 6 feet (1.8 m), nor contact any lower level;
  - (iv) bring an employee to a complete stop and limit maximum deceleration distance an employee travels to 3.5 feet (1.07 m); and,
  - (v) have sufficient strength to withstand twice the potential impact energy of an employee free falling a distance of 6 feet (1.8 m), or the free fall distance permitted by the system, whichever is less.

NOTE: If the personal fall arrest system meets the criteria and protocols contained in Appendix C to subpart M, and if the system is being used by an employee having a combined person and tool weight of less than 310 pounds (140 kg), the system will be considered to be in compliance with the provisions of paragraph (d)(16) of this section. If the system is used by an employee having a combined tool and body weight of 310 pounds (140 kg) or more, then the employer must appropriately modify the criteria and protocols of the Appendix to provide proper protection for such heavier weights, or the system will not be deemed to be in compliance with the requirements of paragraph (d)(16) of this section.

- (17) The attachment point of the body belt shall be located in the center of the wearer's back. The attachment point of the body harness shall be located in the center of the wearer's back near shoulder level, or above the wearer's head.

- (18) Body belts, harnesses, and components shall be used only for employee protection (as part of a personal fall arrest system or positioning device system) and not to hoist materials.
- (19) Personal fall arrest systems and components subjected to impact loading shall be immediately removed from service and shall not be used again for employee protection until inspected and determined by a competent person to be undamaged and suitable for reuse.
- (20) The employer shall provide for prompt rescue of employees in the event of a fall or shall assure that employees are able to rescue themselves.
- (21) Personal fall arrest systems shall be inspected prior to each use for wear, damage and other deterioration, and defective components shall be removed from service.
- (22) Body belts shall be at least one and five-eighths (1 5/8) inches (4.1 cm) wide.
- (23) Personal fall arrest systems shall not be attached to guardrail systems, nor shall they be attached to hoists except as specified in other subparts of this Part.
- (24) When a personal fall arrest system is used at hoist areas, it shall be rigged to allow the movement of the employee only as far as the edge of the walking/working surface.

### **§1926.502(e) Positioning Device Systems**

Positioning device systems and their use shall conform to the following provisions:

- (1) Positioning devices shall be rigged such that an employee cannot free fall more than 2 feet (.6m).
- (2) Positioning devices shall be secured to an anchorage capable of supporting at least twice the potential impact load of an employee's fall or 3,000 pounds (13.3 kN), whichever is greater.
- (3) Connectors shall be drop forged, pressed or formed steel, or made of equivalent materials.
- (4) Connectors shall have a corrosion-resistant finish, and all surfaces and edges shall be smooth to prevent damage to interfacing parts of this system.
- (5) Connecting assemblies shall have a minimum tensile strength of 5,000 pounds (22.2 kN)
- (6) Dee-rings and snaphooks shall be proof-tested to a minimum tensile load of 3,600 pounds (16 kN) without cracking, breaking, or taking permanent deformation.
- (7) Snaphooks shall be sized to be compatible with the member to which they are connected to prevent unintentional disengagement of the snaphook by depression of the snaphook keeper by the connected member, or shall be a locking type snaphook designed and used to prevent disengagement of the snaphook by the contact of the snaphook keeper by the connected member. As of January 1, 1998, only locking type snaphooks shall be used.
- (8) Unless the snaphook is a locking type and designed for the following connections, snaphooks shall not be engaged:
  - (i) directly to webbing, rope or wire rope;
  - (ii) to each other;
  - (iii) to a dee-ring to which another snaphook or other connector is attached;

- (iv) to a horizontal lifeline; or
  - (v) to any object which is incompatibly shaped or dimensioned in relation to the snaphook such that unintentional disengagement could occur by the connected object being able to depress the snaphook keeper and release itself.
- (9) Positioning device systems shall be inspected prior to each use for wear, damage, and other deterioration, and defective components shall be removed from service.
- (10) Body belts, harnesses, and components shall be used only for employee protection (as part of a personal fall arrest system or positioning device system) and not to hoist materials.

### **§1926.502(f) Warning Line Systems**

Warning line systems [See 1926.501(b)(10)] and their use shall comply with the following provisions:

- (1) The warning line shall be erected around all sides of the roof work area.
  - (i) When mechanical equipment is not being used, the warning line shall be erected not less than 6 feet (1.8 m) from the roof edge.
  - (ii) When mechanical equipment is being used, the warning line shall be erected not less than 6 feet (1.8 m) from the roof edge which is parallel to the direction of mechanical equipment operation, and not less than 10 feet (3.1 m) from the roof edge which is perpendicular to the direction of mechanical equipment operation.
  - (iii) Points of access, materials handling areas, storage areas, and hoisting areas shall be connected to the work area by an access path formed by two warning lines.
  - (iv) When the path to a point of access is not in use, a rope, wire, chain, or other barricade, equivalent in strength and height to the warning line, shall be placed across the path at the point where the path intersects the warning line erected around the work area, or the path shall be offset such that a person cannot walk directly into the work area.
- (2) Warning lines shall consist of ropes, wires, or chains, and supporting stanchions erected as follows:
  - (i) The rope, wire, or chain shall be flagged at not more than 6-foot (1.8 m) intervals with high-visibility material;
  - (ii) The rope, wire, or chain shall be rigged and supported in such a way that its lowest point (including sag) is no less than 34 inches (.9 m) from the walking/working surface and its highest point is no more than 39 inches (1.0 m) from the walking/working surface;
  - (iii) After being erected, with the rope, wire, or chain attached, stanchions shall be capable of resisting, without tipping over, a force of at least 16 pounds (71 N) applied horizontally against the stanchion, 30 inches (.8 m) above the walking/working surface, perpendicular to the warning line, and in the direction of the floor, roof, or platform edge;

- (iv) The rope, wire, or chain shall have a minimum tensile strength of 500 pounds (2.22 kN), and after being attached to the stanchions, shall be capable of supporting, without breaking, the loads applied to the stanchions as prescribed in paragraph (f)(2)(iii) of this section; and
- (v) The line shall be attached at each stanchion in such a way that pulling on one section of the line between stanchions will not result in slack being taken up in adjacent sections before the stanchion tips over.
- (3) No employee shall be allowed in the area between a roof edge and a warning line unless the employee is performing roofing work in that area.
- (4) Mechanical equipment on roofs shall be used or stored only in areas where employees are protected by a warning line system, guardrail system, or personal fall arrest system.

### **§1926.502(g) Controlled Access Zones**

Controlled access zones [See 1926.501(b)(9) and 1926.502(k)] and their use shall conform to the following provisions.

- (1) When used to control access to areas where leading edge and other operations are taking place the controlled access zone shall be defined by a control line or by any other means that restricts access.
  - (i) When control lines are used, they shall be erected not less than 6 feet (1.8 m) nor more than 25 feet (7.7 m) from the unprotected or leading edge, except when erecting precast concrete members.
  - (ii) When erecting precast concrete members, the control line shall be erected not less than 6 feet (1.8 m) nor more than 60 feet (18 m) or half the length of the member being erected, whichever is less, from the leading edge.
  - (iii) The control line shall extend along the entire length of the unprotected or leading edge and shall be approximately parallel to the unprotected or leading edge.
  - (iv) The control line shall be connected on each side to a guardrail system or wall.
- (2) When used to control access to areas where overhand bricklaying and related work are taking place:
  - (i) The controlled access zone shall be defined by a control line erected not less than 10 feet (3.1 m) nor more than 15 feet (4.5 m) from the working edge.
  - (ii) The control line shall extend for a distance sufficient for the controlled access zone to enclose all employees performing overhand bricklaying and related work at the working edge and shall be approximately parallel to the working edge.
  - (iii) Additional control lines shall be erected at each end to enclose the controlled access zone.
  - (iv) Only employees engaged in overhand bricklaying or related work shall be permitted in the controlled access zone.
- (3) Control lines shall consist of ropes, wires, tapes, or equivalent materials, and supporting stanchions as follows:
  - (i) Each line shall be flagged or otherwise clearly marked at not more than 6-foot (1.8 m) intervals with high-visibility material.

- (ii) Each line shall be rigged and supported in such a way that its lowest point (including sag) is not less than 39 inches (1 m) from the walking/working surface and its highest point is not more than 45 inches (1.3 m) [50 inches (1.3 m) when overhand bricklaying operations are being performed] from the walking/working surface.
- (iii) Each line shall have a minimum breaking strength of 200 pounds (.88 kN).
- (4) On floors and roofs where guardrail systems are not in place prior to the beginning of overhand bricklaying operations, controlled access zones shall be enlarged, as necessary, to enclose all points of access, material handling areas, and storage areas.
- (5) On floors and roofs where guardrail systems are in place, but need to be removed to allow overhand bricklaying work or leading edge work to take place, only that portion of the guardrail necessary to accomplish that day's work shall be removed.

### **§1926.502(h) Safety Monitoring Systems**

Safety monitoring systems [See 1926.501(b)(10) and 1926.502(k)] and their use shall comply with the following provisions:

- (1) The employer shall designate a competent person to monitor the safety of other employees and the employer shall ensure that the safety monitor complies with the following requirements:
  - (i) The safety monitor shall be competent to recognize fall hazards;
  - (ii) The safety monitor shall warn the employee when it appears that the employee is unaware of a fall hazard or is acting in an unsafe manner;
  - (iii) The safety monitor shall be on the same walking/working surface and within visual sighting distance of the employee being monitored;
  - (iv) The safety monitor shall be close enough to communicate orally with the employee; and
  - (v) The safety monitor shall not have other responsibilities which could take the monitor's attention from the monitoring function.
- (2) Mechanical equipment shall not be used or stored in areas where safety monitoring systems are being used to monitor employees engaged in roofing operations on low-slope roofs.
- (3) No employee, other than an employee engaged in roofing work [on low-sloped roofs] or an employee covered by a fall protection plan, shall be allowed in an area where an employee is being protected by a safety monitoring system.
- (4) Each employee working in a controlled access zone shall be directed to comply promptly with fall hazard warnings from safety monitors.

### **§1926.502(i) Covers**

Covers for holes in floors, roofs, and other walking/working surfaces shall meet the following requirements:

- (1) Covers located in roadways and vehicular aisles shall be capable of supporting, without failure, at least twice the maximum axle load of the largest vehicle expected to cross over the cover.

- (2) All other covers shall be capable of supporting, without failure, at least twice the weight of employees, equipment, and materials that may be imposed on the cover at any one time.
- (3) All covers shall be secured when installed so as to prevent accidental displacement by the wind, equipment, or employees.
- (4) All covers shall be color coded or they shall be marked with the word "HOLE" or "COVER" to provide warning of the hazard.

NOTE: This provision does not apply to cast iron manhole covers or steel grates used on streets or roadways.

### **§1926.502(j) Protection from Falling Objects**

Falling object protection shall comply with the following provisions:

- (1) Toeboards, when used as falling object protection, shall be erected along the edge of the overhead walking/working surface for a distance sufficient to protect employees below.
- (2) Toeboards shall be capable of withstanding, without failure, a force of at least 50 pounds (222 N) applied in any downward or outward direction at any point along the toeboard.
- (3) Toeboards shall be a minimum of 3 ½ inches (9 cm) in vertical height from their top edge to the level of the walking/working surface. They shall have not more than 1/4 inch (0.6 cm) clearance above the walking/working surface. They shall be solid or have openings not over 1 inch (2.5 cm) in greatest dimension.
- (4) Where tools, equipment, or materials are piled higher than the top edge of a toeboard, paneling or screening shall be erected from the walking/working surface or toeboard to the top of a guardrail system's top rail or midrail, for a distance sufficient to protect employees below.
- (5) Guardrail systems, when used as falling object protection, shall have all openings small enough to prevent passage of potential falling objects.
- (6) During the performance of overhand bricklaying and related work:
  - (i) No materials or equipment except masonry and mortar shall be stored within 4 feet (1.2 m) of the working edge.
  - (ii) Excess mortar, broken or scattered masonry units, and all other materials and debris shall be kept clear from the work area by removal at regular intervals.
- (7) During the performance of roofing work:
  - (i) Materials and equipment shall not be stored within 6 feet (1.8 m) of a roof edge unless guardrails are erected at the edge.
  - (ii) Materials which are piled, grouped, or stacked near a roof edge shall be stable and self-supporting.
- (8) Canopies, when used as falling object protection, shall be strong enough to prevent collapse and to prevent penetration by any objects which may fall onto the canopy.

### **§1926.502(k) Fall Protection Plan**



This option is available only to employees engaged in leading edge work, precast concrete erection work, or residential construction work (See 1926.501(b)(2), (b)(12), and (b)(13)) who can demonstrate that it is infeasible or it creates a greater hazard to use conventional fall protection equipment. The fall protection plan must conform to the following provisions.

- (1) The fall protection plan shall be prepared by a qualified person and developed specifically for the site where the leading edge work, precast concrete work, or residential construction work is being performed and the plan must be maintained up to date.
- (2) Any changes to the fall protection plan shall be approved by a qualified person.
- (3) A copy of the fall protection plan with all approved changes shall be maintained at the job site.
- (4) The implementation of the fall protection plan shall be under the supervision of a competent person.
- (5) The fall protection plan shall document the reasons why the use of conventional fall protection systems (guardrail systems, personal fall arrest systems, or safety nets systems) are infeasible or why their use would create a greater hazard.
- (6) The fall protection plan shall include a written discussion of other measures that will be taken to reduce or eliminate the fall hazard for workers who cannot be provided with protection from the conventional fall protection systems. For example, the employer shall discuss the extent to which scaffolds, ladders, or vehicle mounted work platforms can be used to provide a safer working surface and thereby reduce the hazard of falling.
- (7) The fall protection plan shall identify each location where conventional fall protection methods cannot be used. These locations shall then be classified as controlled access zones and the employer must comply with the criteria in paragraph (g) of this section.
- (8) Where no other alternative measure has been implemented, the employer shall implement a safety monitoring system in conformance with 1926.502(h).
- (9) The fall protection plan must include a statement which provides the name or other method of identification for each employee who is designated to work in controlled access zones. No other employees may enter controlled access zones.
- (10) In the event an employee falls, or some other related, serious incident occurs, (e.g., a near miss) the employer shall investigate the circumstances of the fall or other incident to determine if the fall protection plan needs to be changed (e.g. new practices, procedures, or training) and shall implement those changes to prevent similar types of falls or incidents.

### **§1926.503(a) Training Program**

The following training provisions supplement and clarify the requirements of 1926.21 regarding the hazards addressed in subpart M of this part.

- (1) The employer shall provide a training program for each employee who might be exposed to fall hazards. The program shall enable each employee to recognize the hazards of falling and shall train each employee in the procedures to be followed in order to minimize these hazards.
- (2) The employer shall assure that each employee has been trained, as necessary, by a competent person qualified in the following areas:
  - (i) The nature of fall hazards in the work area;

- (ii) The correct procedures for erecting, maintaining, disassembling, and inspecting the fall protection systems to be used;
- (iii) The use and operation of guardrail systems, personal fall arrest systems, safety net systems, warning line systems, safety monitoring systems, controlled access zones, and other protection to be used;
- (iv) The role of each employee in the safety monitoring system when this system is used;
- (v) The limitations on the use of mechanical equipment during the performance of roofing work on low-sloped roofs;
- (vi) The correct procedures for the handling and storage of equipment and materials and the erection of overhead protection; and
- (vii) The role of employees in fall protection plans;

NOTE: OSHA Subpart M does not require a fall protection plan unless the employer is using alternative fall protection methods to protect employees performing leading-edge work, precast concrete erection, or residential construction (§1926.501(b)(2)(i), (12), and (13), respectively). Those three provisions allow employers engaged in the work specified to develop and implement a fall protection plan that uses alternative fall protection methods if they can demonstrate the infeasibility of conventional fall protection. (Standard Interpretation Letter)

- (viii) The standards contained in this subpart (29 CFR 1926 Subpart M).

### **§1926.503(b) Certification of Training**

- (1) The employer shall verify compliance with paragraph (a) of this section by preparing a written certification record. The written certification record shall contain the name or other identity of the employee trained, the date(s) of the training, and the signature of the person who conducted the training or the signature of the employer. If the employer relies on training conducted by another employer or completed prior to the effective date of this section, the certification record shall indicate the date the employer determined the prior training was adequate rather than the date of actual training.
- (2) The latest training certification shall be maintained.

### **§1926.503(c) Retraining**

When the employer has reason to believe that any affected employee who has already been trained does not have the understanding and skill required by paragraph (a) of this section, the employer shall retrain each such employee. Circumstances where retraining is required include, but are not limited to, situations where:

- (1) Changes in the workplace render previous training obsolete; or
- (2) Changes in the types of fall protection systems or equipment to be used render previous training obsolete; or
- (3) Inadequacies in an affected employee's knowledge or use of fall protection systems or equipment indicate that the employee has not retained the requisite understanding or skill.